

## **Part I**

### **Basic Operation of SPR**

## Chapter I General Introduction of SPR

SPR intelligent controller is a new type of programmable controller. It is programmed by the use of a Function Block Diagram. The programming of SPR is simpler and easier to learn than the programming of a conventional PLC, that uses ladder diagrams and associated instructions. The design concept, for the SPR series of products, includes a removable LCD panel. The program can be written directly into the SPR using this LCD panel. After programming the LCD panel can be retained or removed and replaced with a cover. The cost to the user can be reduced by multiple use of the LCD panel. The use of a computer is recommended for more complex control schemes.

Products within the SPR series are very compact and light in weight. SPR intelligent controls series can be used for both local and remote control, communication, networking and monitoring. SPR series can realize telephone-control, voice alarm and information, automatic dialing using the associated AF-MUL unit. SPR is widely used in many fields of industry, commerce, mining, agriculture, home automation etc.

### 1.1 Structure of SPR

Main Hardware Structure of SPR includes:

- ▲ Basic Function Blocks and Special Function Blocks
- ▲ Operation Display Panel
- ▲ Real-time Clock Circuit
- ▲ Programming Interface
- ▲ Voice Module/ Remote-control Module/ Extended Module
- ▲ Input & Output Terminal

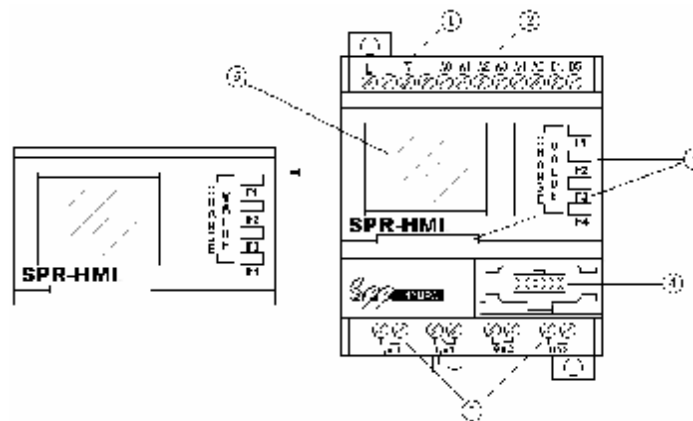
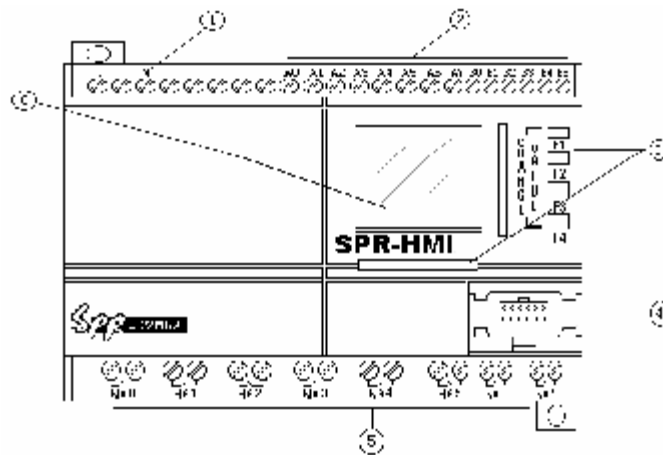

Fig.1.1 SPR Series Shape

1. Input of Power (AC or DC) (AC100-240V), (DC12-24V)
2. Input Terminal
3. SPR-HMI
4. Communication Interface
5. Output Terminal
6. LCD Display Panel



**Fig.1.2 SPR-22 Series Shape**

1. Input of Power (AC or DC) (AC100-240V), (DC12-24V)
2. Input Terminal
3. SPR-HMI
4. Communication Interface
5. Output Terminal (Output of relay or electronic transistor)
6. LCD Display Panel

### 1.2 Naming Rules of SPR Series Products

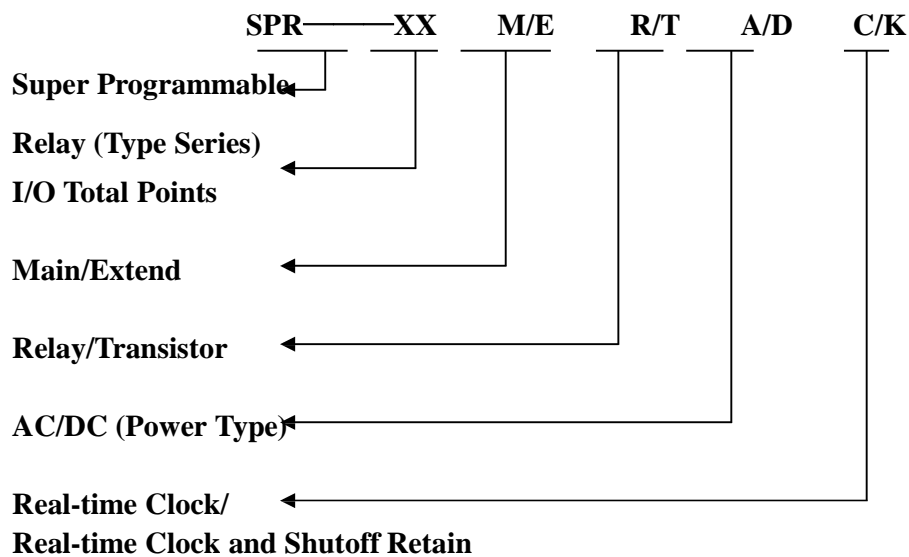

**Note:** M means machine, E means extend

A means AC type, D means DC type

G means with real-time clock,

K means with real-time clock and shutoff retaining

### 1.3 Specification and Type of SPR

Type	Power	Input	Output	Remarks
SPR-12MRAC	AC100-240V	8 points AC input	4 point relay output	With real-time clock
SPR-12MRDC	DC12-24V	8 points DC input	4 point relay output	With real-time clock
SPR-12MTDC	DC12-24V	8 points DC input	4 point transistor output	With real-time clock
SPR-22MRAC	AC100-240V	14 points AC input	8 point relay output	With real-time clock
SPR-22MRDC	DC12-24V	14 points DC input	8 point relay output	With real-time clock
SPR-22MTDC	DC12-24V	14 points DC input	8 point transistor output	With real-time clock
SPR-20ERA	AC100-240V	12 point AC input	8 point relay output	20 point extended module
SPR-20ERD	DC12-24V	12 point DC input	8 point relay output	
SPR-20ETD	DC12-24V	12 point DC input	8 point transistor output	
SPR-VPA	AC100-240V	Voice module, auto-dialing alarming telephone and remote control by telephone		
SPR-VPD	DC12-24V			
SPR-RAC	AC100-240V	Remote control receiving module		
SPR-RCD	DC12-24V			
SPR-TC	3VDC (two units No. 5 batteries)		Remote control transmitter	
SPR-HMI	LCD programming panel			
SPR-CBA	AC type	Connecting bridge, to connect the machine and the external expanded model.		
SPR-CBD	DC type			
SPR-CPA	AC type	Communication cable, the communication connection cable between SPR and PC, to realize the monitoring function of the PC to the machine.		
SPR-CPD	DC type			
SPR-PC	The cover			
SPR-ECBA	AC type (one on each side)		To remotely connect the machine and the extended module.	
SPR-ECBD	DC type (one on each side)			
SPR-EHC	Connection set of SPR-HMI Remotely connect SPR machine and SPR-HMI to place the SPR machine and so on into the case conveniently and put the SPR-HMI out the case for observation and operation.			
SPR-LC	Cover for the bridge. (If using SPR-CBA or SPR-CBD, then it is no need to use this cover.) (One on each side).			
SPR-EANT	Long connecting antenna of SPR-RCA/SPR-RCD			
SPR-AUD	The recording microphone and the wires between the sound card and the SPR-VPA/SPR-VPD.			
SPR-WRT	Programming Panel			
SPR-CMT	Front-putting Communication Machine			

#### Explanation:

The types, which are divided into the AC or DC type, must be in the system all the machines are of one power input type, if they want to be set and used into a system. That is to say that, the machine of AC type must be used with AC type extended module and other machines of AC type. And the machine of DC type must be used with DC type extended module and other machines of DC type.

## 1.4 Features of SPR

### 1. Removable programming panel with Liquid Crystal Display

There is an operating panel with LCD display on the front side of SPR. You can use the operating keys on this panel to edit directly the control program for SPR. It can remove the LCD from the machine by the private interface to program remotely. Moreover, this LCD display panel is removable, and it can be set up according to your needs. When needed, it can be plugged in. When not needed, it can be removed and replaced with a front cover.

---

#### Warning

*The LCD display panel shall be plugged in or removed only after AC or DC power has been turned off.*

---

### 2. Flexible LCD Display Interface

Comparison with conditional LCD, here we provide 64 human-machine interfaces. When using Super Relay Logic, users can add the human-machine interface no more than 64 according to the need. It will display the following data, such as time, status of input & output, counter, timer, analog and so on. When using, user can modify, add or delete the interface. Thus a free and easily using LCD module is given to the user.

### 3. Well featured and compact design

If you are thinking of improving the application of your equipment, SPR provides very many features. SPR is very compact.

71mmX106mmX67mm	(12 points type/voice module)
126mmX106mmX67mm	(22 points type/20points extended type/remote control receiver)

4. With the function blocks used for programming, the program storage capacity of SPR is large.

The control functions of SPR can be implemented only with function blocks incorporated into a function block diagram. The same level of control implemented by a conventional PLC would require a much larger and more detailed program. When several function blocks are linked together in a specific way, then relatively complicated control functions can be implemented. SPR has a storage capacity of programs for up to 127 function blocks. There is a large application resource to satisfy the requirements for complicated control. A program, when downloaded into SPR will never be lost as SPR does not rely on a battery for the memory function.

### 5. External Extendable Input/output

SPR series machine can connected with the relative SPR-20E Extended Module. Thus it can be extended to 20 points input/output once (12 points input and 8 points output). One set of SPR series machine can be externally connected with 5 extended modules. Thus 22 points machine can be extended to 120 points input/output (74 points input and 48 points output). And it gives you a large storage capacity.

#### **6. Real time clock function**

SPR series intelligent controller has the real time clock recording function. It can run and time according to the random time of your desiring and the accuracy can reach second, which make your control of time be correct and accurate. And you can set 127 periods of different time. It is suitable for the system that needs the time control.

#### **7. Analog input and transmission**

In addition to receiving a switching input, SPR can also receive the analog input to implement the control of temperature, humidity, pressure, flow, level unit, etc., and transmit them remotely to a computer for monitoring.

#### **8. Write the program online**

SPR series intelligent controller adds the function of writing the program online. It can be updated and upgraded at any time according to the source program code. When SPR series product being updated, you may update your system through the internet.

#### **9. Security cipher code function**

SPR is provided with protection for the programs downloaded into it. A security cipher code can be set before programs are written. The programs can then only be modified after the correct cipher code is entered.

#### **10. Telephone function**

SPR is equipped with telephone and voice function blocks. It is possible to dial directly through a telephone line after the required telephone number has been preset. SPR can be dialed automatically, when the conditions are satisfied so as to implement advice or alarm functions. Moreover, SPR can also receive remote signals transmitted through a telephone line in order to control the terminal equipment.



*It is necessary to configure SPR-VPA/VPD multifunctional voice block for the implementation of telephone function and voice function.*

---

#### **11. Wireless Control**

Wireless control functions can wirelessly remote control the SPR to realize the control to the voice module, input/output. This function can be used in some specific control site, such as the control to the start and stop of SPR with no means by hands, or control the SPR at site in the working house. Using wireless control module it will be readily solved. In general, wireless control function can make it convenient to realize the control to the SPR.

## **12. Voice function**

**SPR can provide voice recording and broadcasting back functions for the automatic control industry, creating intelligent controls which can give audible voice outputs, both locally and through remote speakers.**

## **13. Function Keys**

**32 function keys are provided. The function of these keys is the same as IN (Input I0-In), relatively the same as the soft switch. On the LCD panel, all the defined function keys are displayed. Also the explanation and the password protection function of each function key can be show in Super Relay Logic. The Super Relay Logic provides 8 function keys pages and in each page there may be 4 function key.**

## **14. Super Relay Logic: Programming Software**

**The control program can be downloaded directly, with the use of the LCD panel, into a SPR unit. With more complicated control schemes the use of an ancillary computer, loaded with SUPER RELAY LOGIC software, is recommended. The control program can then be written into the memory of the SPR is a very friendly human-machine interface programming software. It can edit the function diagrams and also can analogously run the written program. It provides an off-line testing function to the user. This feature overcomes much of the possible inconveniences normally experienced with on-line testing and commissioning. The system can be proven before being put into actual service. SUPER RELAY LOGIC will not only guide you to implement the editing of the control programs, but will also perform the real-time monitoring for the field environment and the operational conditions of SPR.**

## Chapter II Installation of SPR

### 2.1 Installation Method

SPR is small and it is suitable for fitting inside panels or machinery within its specification criteria. The installation of SPR is quite simple:

1. Use a standard DIN rail for installation of SPR as shown in Fig. 2.1.
2. Use the two diagonal clearance holes on SPR for direct mounting.



Fig. 2.1 Use standard DIN rail for installation of FAB

---

### ⚠ Notes:

1. The LCD of the SPR is removable. Hold the two sides of the machine and pull.
  2. Do not remove the LCD panel while the FAB is powered, otherwise the FAB and LCD panel may be damaged and endanger the personal safety of the user.
- 

### 2.2 Installation Dimensions

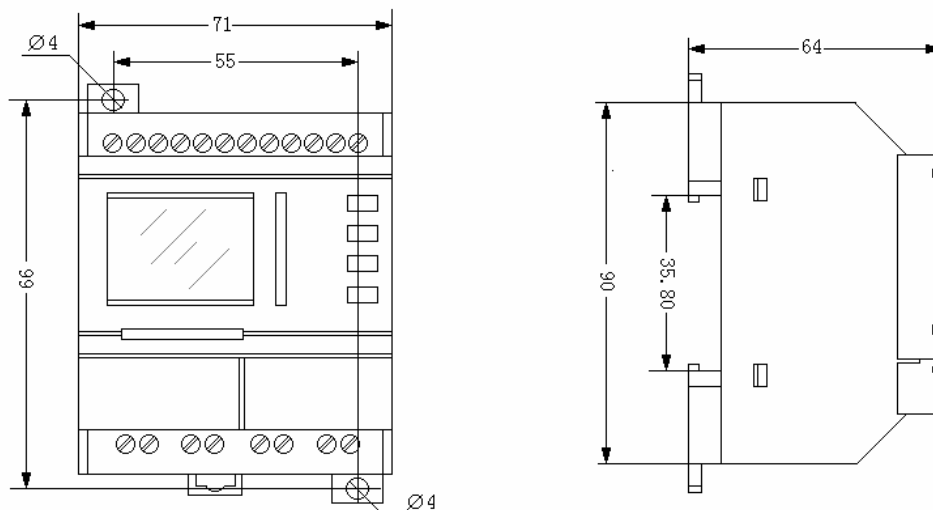
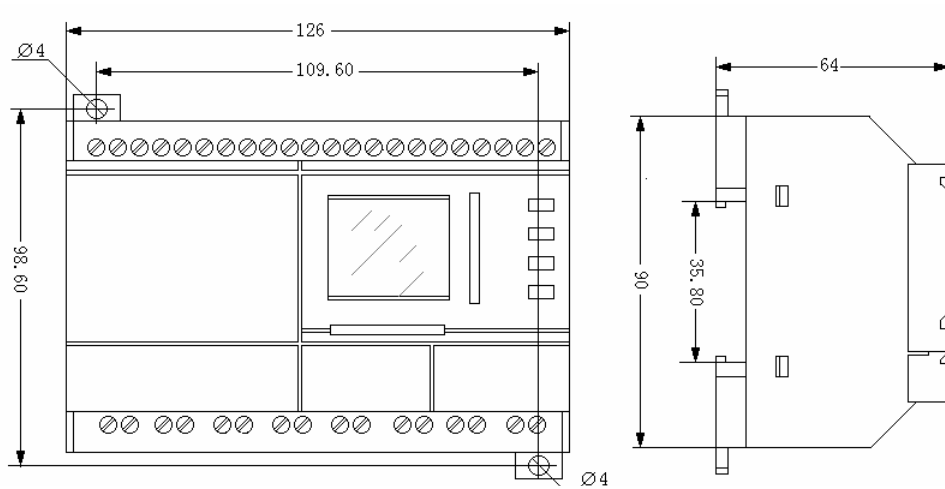
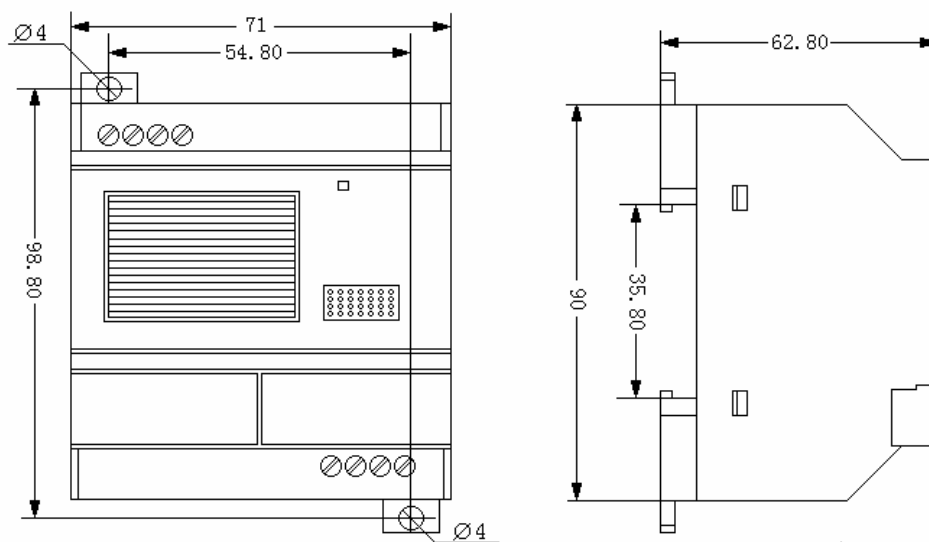

Fig. 2.2 Installation Dimensions of SPR-12 Series (mm)



**Fig. 2.3 Installation Dimension of SPR-22 Series (mm)**



**Fig. 2.4 Installation Dimensions of SPR-VP Series Voice Module (mm)**

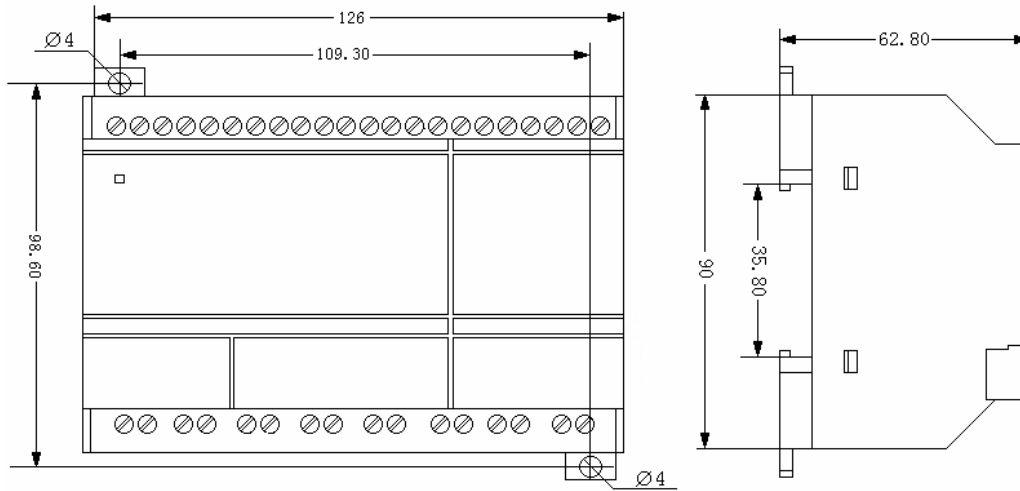

Fig.

### 2.5 Installation Dimensions of SPR-20 and SPR-RC Series (mm)

### 2.3 Wiring of SPR

A screwdriver with a spade tip width of 3mm is used for the wiring of FABs. The maximum cross sections of the wires that can be inserted into the terminals are determined according to the following sizes:

- ※ 1x2.5mm<sup>2</sup>
- ※ 2x1.5mm<sup>2</sup>

#### 2.3.1 Connection of the power

1. SPR-12MRA, SPR-22MRA, SPR-20ERA, SPR-VPA, SPR-RCA are AC types. The rated power supply requirement for them is 110-240VAC, 50/60HZ. The range of the grid voltage is 110VAC to 220VAC. The consumption power of SPR-12MRA and SPR-22MRA is 3W and 5W representively.

2. SPR-12MRD, SPR-12MTD, SPR-22MRD, SPR-22MTD, SPR-20ERD, SPR-20ETD, SPR-VPD, SPR-VCD are DC types. The supplying DC voltage is 24VDC. The range of the voltage is 12VDC to 24VDC. The consumption power of SPR-12MTD and SPR-22MTD is 2W .

The power connection for FABs is as shown in the following drawings:

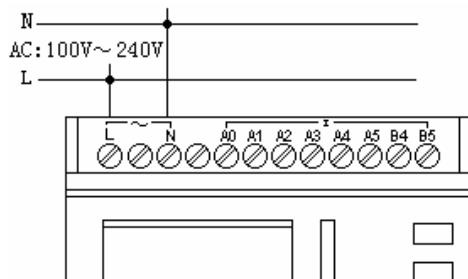

Fig. 2.6 AC Type

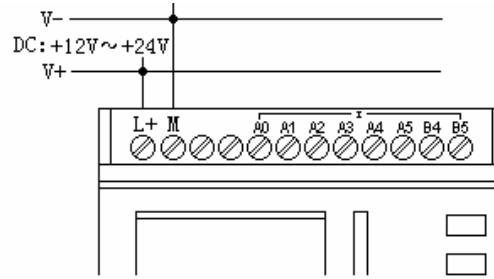

Fig. 2.7 DC Type

### 2.3.2 Connecting SPR Input

The input to FAB can be either digital, such as on/off switches etc., or analog, such as pressure, temperature, humidity, flow, etc. The specific requirements are as follows:

Type \ Demand	SPR-12MRAC	SPR-12MRDC	SPR-12MTDC
	SPR-22MRAC	SPR-22MRDC	SPR-22MTDC
Switch Status 0	<40VAC	<5VDC	<5VDC
Input Current	<0.24mA	<1.5mA	<2.8mA
Switch Status 1	≥85VAC	≥10VDC	≥10VDC
Input Current	Typical 0.24 mA	Typical 3mA	Typical 3 mA
Analogue Input	No	A0~A5/A0~A7	A0~A5/A0~A7

**Note:**

1. For SPR-12MRDC, SPR-12MTDC, SPR-22MRDC and SPR-22MTDC that can receive analog input. They can be set to analog input or digital input as either may be used in the program. They will be recognized as analog inputs when the input terminal is connected with an analog function block, and they will be recognized as digital inputs when the input terminal is not connected with an analog function block.
2. The analog inputs require 0V ~ +10V voltage signals. These are divided equally in 0.1V increments. In programming, all the block parameters related to the analog inputs are based on the minimum increment of 0.1V.
3. They can be recognized as digital input when the input voltage is more than 10.0V and cannot be recognized as an analog input.
4. For the digital input off, when the switch status changes from 0 to 1, the time of Status 1 must be greater than 50ms, and when the switch status changes from 1 to 0, the time of Status 0 also must be greater than 50ms.

Connecting SPR is shown as in the following figures:

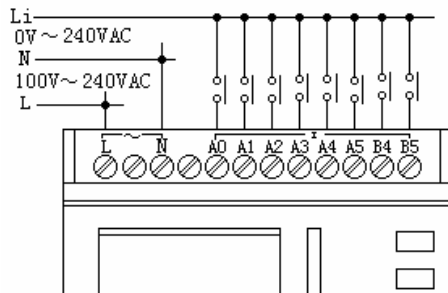

Fig. 2.8 AC Type

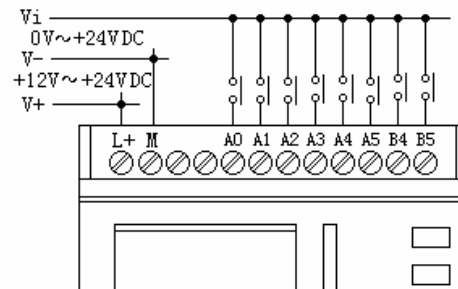
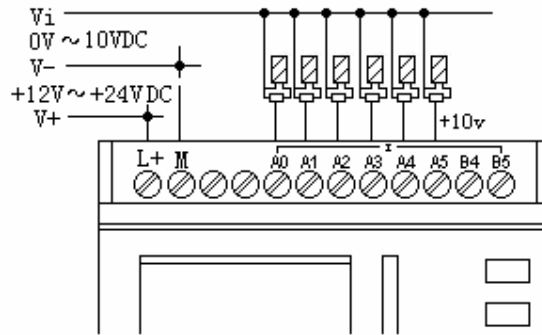

Fig. 2.9 DC Type

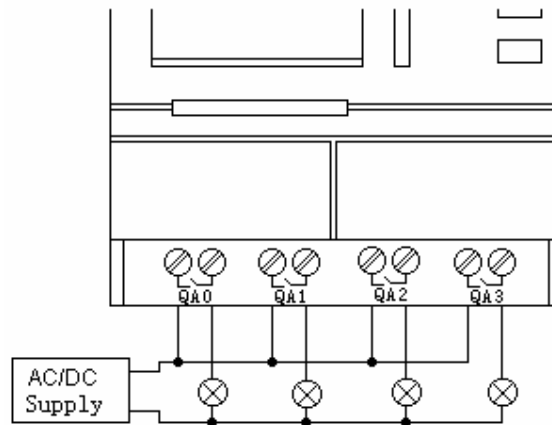

**Fig. 2.10 DC Type (Analog)**

### 2.3.3 Connecting of SPR Output

#### 1. Requirement for the relay output

Various loads such as lamp, fluorescent tube, motor, contactor, etc., can be connected to the outputs of SPR. The max. ON output current that can be supplied by SPR, is 10A for the resistance load and 2A for the inductive load. The connection is in accordance with the following figure 2.11:



**Fig. 2.11 Relay Output**

#### 2. Requirement for the electronic transistor output:

The load connected to FAB must have the following characteristics:

The maximum switch current cannot exceed 2A when the switch is ON ( $Q=1$ ), the maximum current is 2A.

The connection is in accordance with the following figure 2.12:

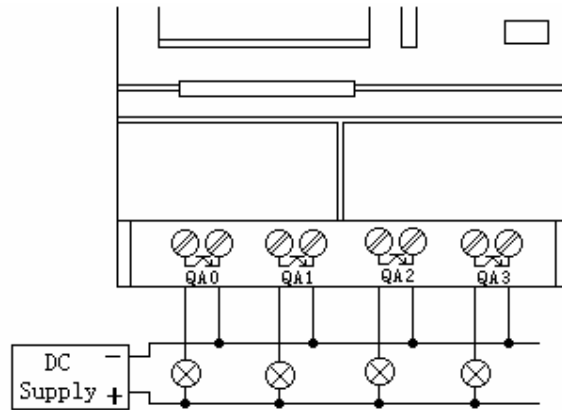

**Fig. 2.12 Transistor Output**

---

**⚠ Notes:**

- 1. The connecting voltage must be lower than 24VDC and the load voltage must be DC.*
  - 2. The “+” terminal of the output wiring must be connected with DC positive voltage and the voltage must be lower than 24VDC, and “-” terminal must be connected with the “M” terminal of the SPR power.*
  - 3. The output terminal must be connected with a load.*
- 

**2.3.4 SPR Series Products Connecting**

SPR series machine can be connected with voice module, remote control module, extended module together and use. They must be the same type. That is to say that the AC types are connected with the AC types and the DC types are connected with the DC types.

- 1. The connecting diagram of SPR-12MRAC and SPR-20ERA, SPR-RCA or SPR-VPA**

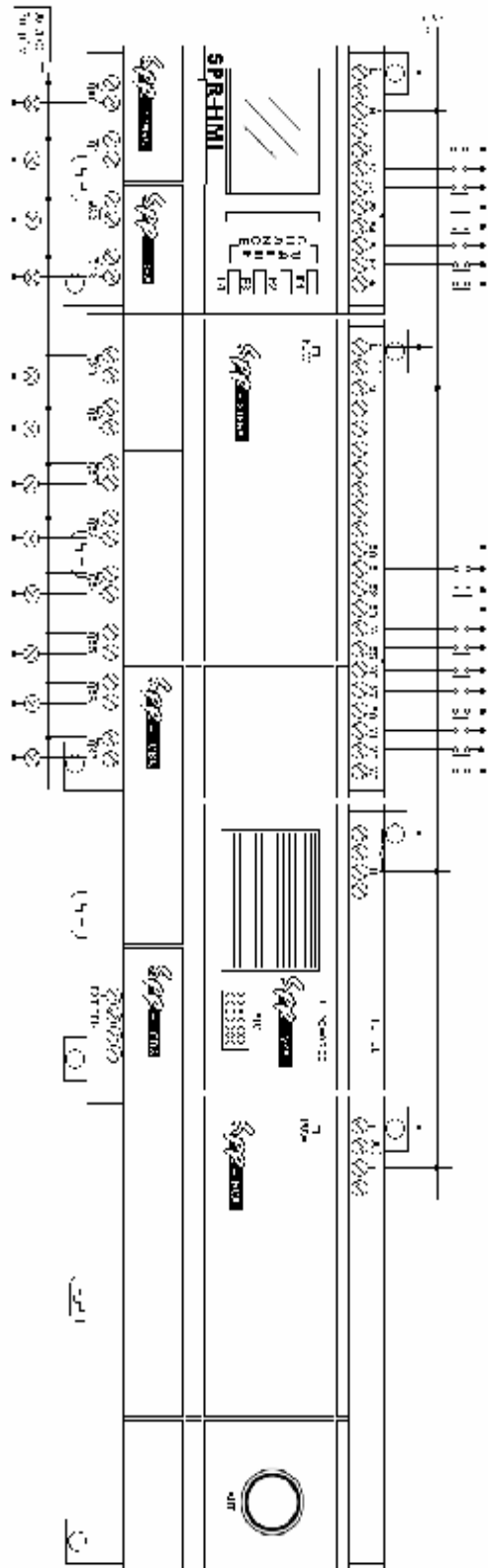

Fig. 2.13 Connecting Diagram of SPR-12MRA and SPR-20ERA, SPR-RCA or SPR-VPA

## 2. SPR-12MRD and SPR-20ERD, SPR-RCD or SPR-VPD Connecting Diagram

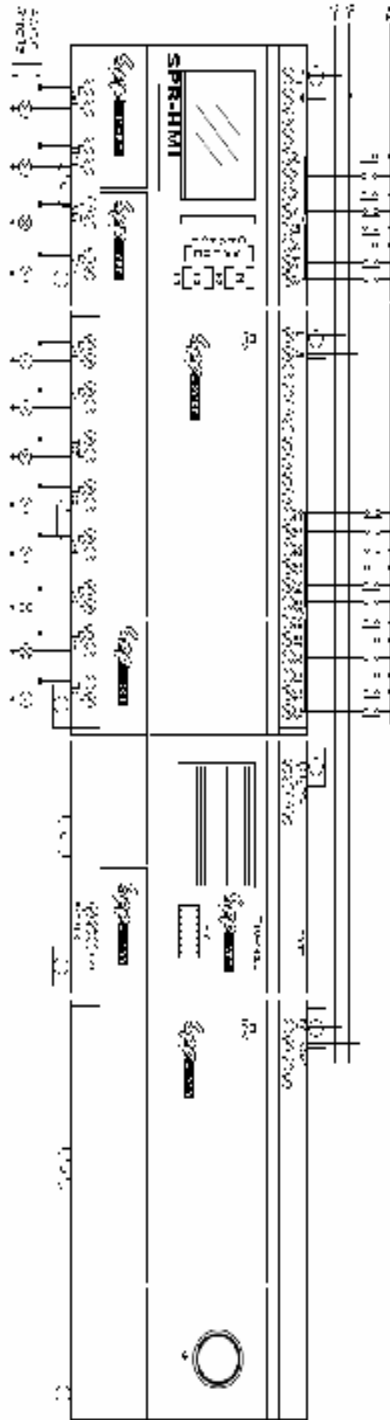

Fig.2.14 Connecting diagram of SPR-12MRD and SPR-20ERD, SPR-RCD or SPR-VPD



Notes:

*Range of the input voltage is DC 0-24V, and output control voltage is AC or DC type (AC is 0-24V, and DC is 0-24V.)*

---

### 3. SPR-12MTD and SPR-20ETD, SPR-RCD or SPR-VPD Connecting Diagram

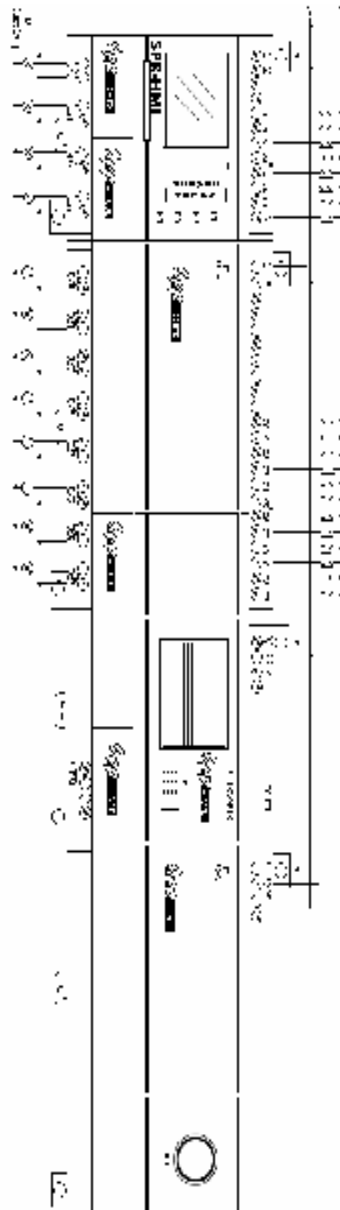

Fig.2.15 Connecting diagram of SPR-12MTD and SPR-20ETD, SPR-RCD or SPR-VPD

---

**⚠ Notes:**

- 1. The connecting voltage of the transistor type output control must be • 24VDC and the load voltage must be DC.*
  - 2. Each machine can be connected with 5 extended modules, one voice module and a remote control module at most.*
  - 3. The address of the extended module is set to be 1-5. (For details please consult the contents of Chapter VII)*
  - 4. The AC type machine must externally be connected with voice module, extended module and remote control of AC type. And the same with the DC type machine.*
-



- 1. Current safety regulations do not permit the connection of different phases to the input.*
  - 2. Power and input must same phases*
  - 3. Do not touch of the input and output points and power input points at SPR working.*
  - 4. Don't touch or take down the link bridge SPR-CBA/CBD at SPR working.*
-

## Chapter III General Description of Function Block

SPR series adopts the programming method with the use of function blocks. 28 function blocks are configured in total, and each block can achieve a specific control function independently, e.g. TOND, TOFD, SBPL, SBPL, SCHD, etc. As several blocks are linked up in a specific way relatively complicated control functions can be realized. Programming with function blocks is simpler and better appreciated than the conventional PLC instruction programming.

The following types of operator for FAB function blocks are available for options:

1. Options of input port: IA0~IA7, IB0~IB5 (input port of 22-point machine), IC0~IC7, ID0~ID5 (input port of extended module 1), IE0~IE7, IF0~IF5 (input port of extended module 2), IG0~IG7, IH0~IH5 (input port of extended module 3), II0~II7, IJ0~IJ5 (input port of extended module 4), IK0~IK7, IL0~IL5 (input port of extended module 5), M00—M99, N00—N99 (intermediate relay), V00~V99 (virtual keys), HI (high potential status), LO (low potential status), X (no input connection), telephone two-tone pulse: P00--P99.
2. Options of output port: QA0~QA7 (output port of the machine), QC0~QC7 (output port of extended module 1), QE0~QE7 (output port of extended module 2), QG0~QG7 (output port of extended module 3), QI0~QI7 (output port of extended module 4), QK0~QK7 (output port of extended module 5), M00—M99, N00—N99 (intermediate relay)

### 3.1 Basic Function Blocks (GF)

There are 8 general function blocks in total as listed in the following table:

**Table 1: General Function Blocks**

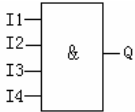
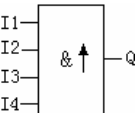
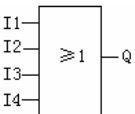
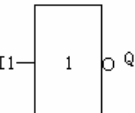
Line Diagram	SPR Function Block	Function
Series connection Of NO contacts		AND
Series connection of NO contacts with RLO borderline test		ANDL (With RLO borderline test)
Parallel connection Of NO contacts		OR
Phase inverter		NOT

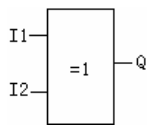
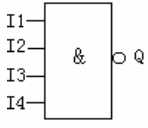
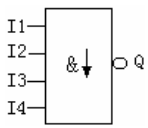
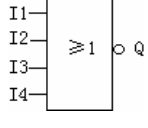
<b>Dual communicator contact</b>		<b>XOR</b>
<b>Parallel connection Of NC contacts</b>		<b>NAND</b>
<b>Parallel connection of NC contacts with RLO borderline test</b>		<b>NANDL (With RLO borderline test)</b>
<b>Series connection Of NC contacts</b>		<b>NOR</b>

### 3.1.1 AND

Series connection of a certain number of NO contacts is shown in the SPR line diagram as follow:

In SPR, the symbol of AND is the follows:

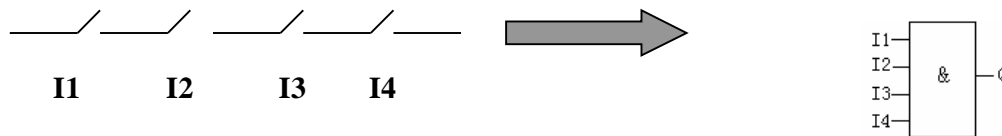

This function block is called as AND, because only when all of I1, I2, I3 and I4 are all in status 1, the status of Output Q will be 1 (i.e. the output is closed).

Logical frame of AND:

I1	I2	I3	I4	Q
0	0	0	0	0
0	0	0	1	0
0	0	1	0	0
0	0	1	1	0
0	1	0	0	0
0	1	0	1	0
0	1	1	0	0
0	1	1	1	0
1	0	0	0	0
1	0	0	1	0
1	0	1	0	0
1	0	1	1	0
1	1	0	0	0
1	1	0	1	0
1	1	1	0	0
1	1	1	1	1

### 3.1.2 AND with RLO Borderline Test

In SPR, the symbol is as shown in the follows:



Only when all the status of the input is 1 and at least the status of one input is 0 in the last period, the output status of AND with RLO borderline test is 1.

If the input line of this function block (X) is unconnected, then this input is X=1.

The time diagram of AND with RLO borderline test is as shown in the follows:

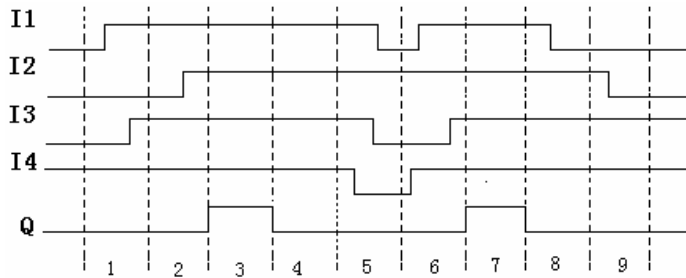

### 3.1.3 OR

Parallel connection of a certain number of NC contacts is shown in the SPR line diagram as follows:

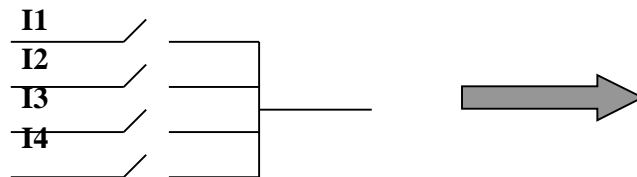

In SPR, the symbol of OR is as shown in the follows:

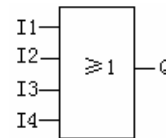

This function block is called as OR, because the status for at least one of the inputs I1, I2, I3 or I4 is 1 (i.e. closed), then output Q is 1.

Logic frame of OR:

I1	I2	I3	I4	Q
0	0	0	0	0
0	0	0	1	1
0	0	1	0	1
0	0	1	1	1
0	1	0	0	1
0	1	0	1	1
0	1	1	0	1
0	1	1	1	1
1	0	0	0	1
1	0	0	1	1
1	0	1	0	1
1	0	1	1	1
1	1	0	0	1
1	1	0	1	1
1	1	1	0	1
1	1	1	1	1

### 3.1.4 NOT

The phase inverter is indicated in

The symbol of NOT is as shown

the SPR line diagram as follows:

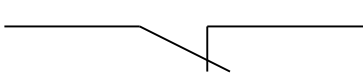

in the follows:

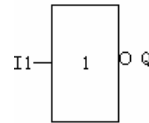

This function block is called as NOT, because the input status is 0, output Q is 1, and vice versa. In other words, NOT is the phase inverter for the input point.

Logic frame of NOT:

I1	Q
0	1
1	0

### 3.1.5 XOR

As shown in the line diagram, the two commutator contacts for XOR are connected in serial as follows:

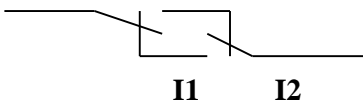

In SPR, the symbol of XOR is shown as follows:

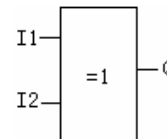

When the status of input are not the same, the output status of XOR is 1.

When the status of input are the same, the output status of XOR is 0.

Logic frame of XOR:

I1	I2	Q
0	0	0
0	1	1
1	0	1
1	1	0

### 3.1.6 NAND

Parallel connection of a certain number of NC contacts is shown in the SPR line diagram as follows:

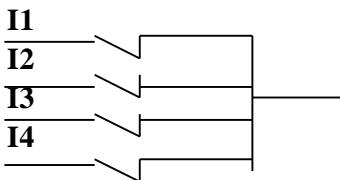

The symbol of NAND is as shown in the follows:

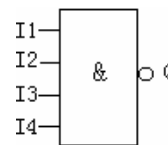

Logic frame of NAND:

I1	I2	I3	I4	Q

0	0	0	0	1
0	0	0	1	1
0	0	1	0	1
0	0	1	1	1
0	1	0	0	1
0	1	0	1	1
0	1	1	0	1
0	1	1	1	1
1	0	0	0	1
1	0	0	1	1
1	0	1	0	1
1	0	1	1	1
1	1	0	0	1
1	1	0	1	1
1	1	1	0	1
1	1	1	1	0

### 3.1.7 NAND with RLO Borderline Test

In SPR, the symbol is as shown in the follows:

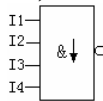

Only when the status of at least one of the input is 0 and status of all the input in the last period are 1, the output status of this NAND with RLO borderline test is 1.

If one input line of this function block (X) is unconnected, then the status of this input is X=1.

Time diagram of NAND with RLO borderline test is as shown in the follows:

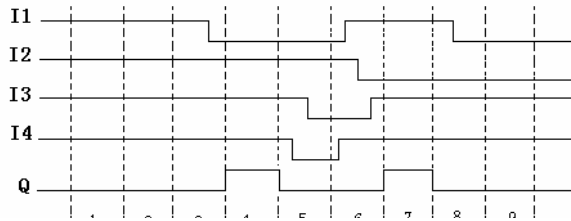

### 3.1.8 NOR

Serial connection of a certain NC contacts is shown in the line Diagram as follows:

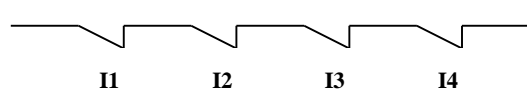

In SPR, the symbol of NOR is as shown in the follows:

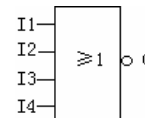

In NOR function block, when the status of all the inputs is low potential (status 0), then the output is connected (status 1). If any one of the input is high potential (status 1), then the output is opened (status 0).

Logic frame of NOR:

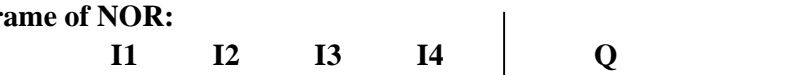

0	0	0	0	1
0	0	0	1	0
0	0	1	0	0
0	0	1	1	0
0	1	0	0	0
0	1	0	1	0
0	1	1	0	0
0	1	1	1	0
1	0	0	0	0
1	0	0	1	0
1	0	1	0	0
1	0	1	1	0
1	1	0	0	0
1	1	0	1	0
1	1	1	0	0
1	1	1	1	0

### 3.2 Special Function Block (SF)

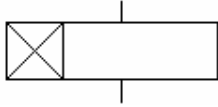
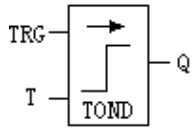
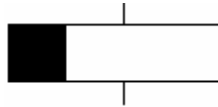
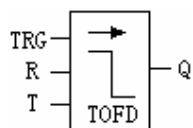
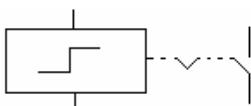
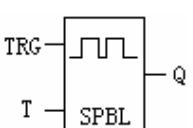
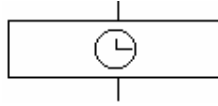
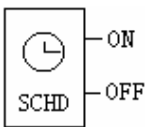
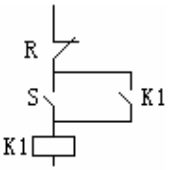
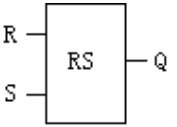
Function	Representation	Graphic
<b>TOND</b>		
<b>TOFD</b>		
<b>SBPL</b>		
<b>SCHD</b>		
<b>TPBL</b>		

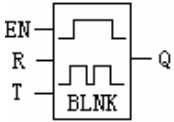
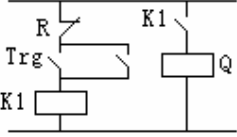
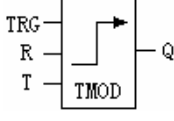
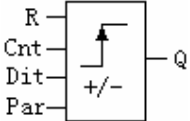
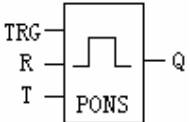
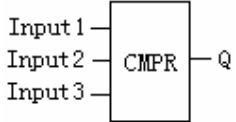
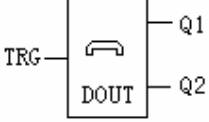
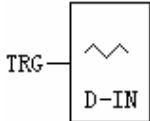
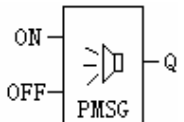
<b>BLNK</b>		
<b>TMOD</b>		
<b>UDCT</b>		
<b>PONS</b>		
<b>CMPR</b>		
<b>DOUT</b>		
<b>D-IN</b>		
<b>PMSG</b>		

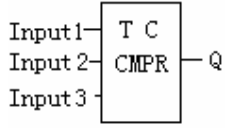
<p><b>Comparator of time and count</b></p>		
--	--	--

### 3.2.1 TOND

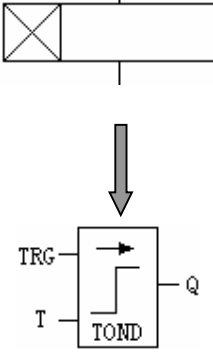
Line diagram/Symbol in SPR	Pin	Description
	<p><b>Input TRG</b></p>	<p>After TRG is triggered, the time delay timer starts timing. (If TRG stop triggering during the timing of timer, the timer will terminate the timing.)</p>
	<p><b>Parameter T</b></p>	<p>After time T, the output is on (the output signal changes from 0 to 1).</p>
	<p><b>Output Q</b></p>	<p>If there is still trigger signal, when time T is up, the output will be on.</p>

**Time Sequence Frame:**

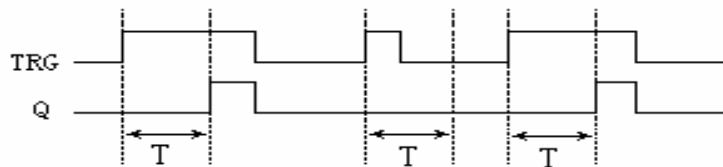

**Function Description:**

1. When the status of TRG changes from 0 to 1, the time delay timer starts timing. If TRG holds the status 1 for a sufficiently long time, the output will be changed to 1 after the time T has elapsed. There is a time delay between the input turning ON and the output turning ON, that why the TOND is so called.
2. If the status of TRG input changes into 0 before the fixed time, the timer will be reset.
3. When the status of TRG input is 0, then the reset status of the output is 0.
4. This function is applicable to override vibrations of switches, delayed start-up of motor, delayed turning-on of lights, etc.
5. The assignment range for T is 0.01-99.99, and the time units can be set respectively to hour (H), minute (M) and second (S). Its time accuracy can reach 0.5%.

### 3.2.2 TOFD

Line diagram/Symbol in SPR	Pin	Description
----------------------------	-----	-------------

	<b>Input TRG</b>	Turn on the timer of the time-delay off relay, when the input TRG (trigger) is at the descending edge (changing from 1 to 0).
	<b>Input R</b>	The timer of disconnecting time-delay relay is reset via R (Reset Input), and Output Q is set to 0. (R has higher priority to TRG.)
	<b>Parameter T</b>	The output is disconnected (the Q status is changed from 1 to 0), when the time T elapses.
	<b>Output Q</b>	Input TRG is activated then the output is turned on (Q=1) and is kept ON until it is reset when the set time T is up.

**Time Sequence Frame:**

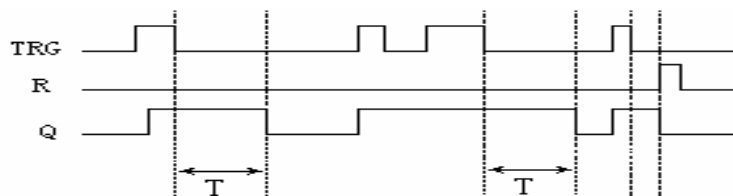

**Function description:**

1. When Input TRG is Status 1, Output Q is changed at once to Status 1. When Input TRG is changed from 1 to 0 (when the descending edge comes), the internal time delay timer of FAB is activated and Output Q is still remained in status 1. When the set time T is up, Output Q becomes 0 and the timer is reset 1.
2. If Input TRG changes from Status 1 to Status 0 again, the timer is activated again.
3. Before the set time T is up, the timer and output can be reset via R (Reset) input
4. This function is applicable to the lighting of staircase, the control of barriers in a car park, the control of a water throttling valve, etc.
5. The assignment range of T is 0.01-99.99, and the time units can be set respectively to hour (H), minute (M), second (S).
6. TRG and R terminals are treated as Status 0 if they are set as X..

**3.2.3 SPBL**

Line diagram/ Symbol in SPR	Pin	Description
--------------------------------	-----	-------------

	<b>Input TRG</b>	Trigger input (TRG) makes the output ON and OFF.
	<b>Input R</b>	The output Q is reset via R (Reset Input). (Q=0, R has a higher priority to TRG.)
	<b>Output Q</b>	Every time TRG changes from 0 to 1, the status of Q will be changed (i.e. from Status 0 to Status 1 or vice versa).

**Time Sequence Frame:**

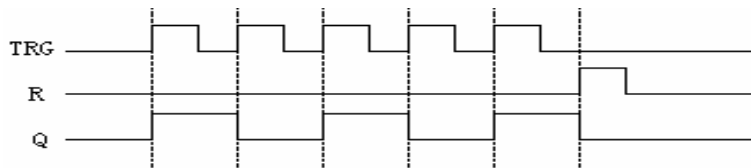

1. Every time the trigger input TRG changes from Status 0 to Status 1, the status of Output Q will change accordingly (The status of Q will be reversed).
2. Reset Q to Status 0 via Input R.
3. After the power is ON or OFF, the pulse relay is reset and Output Q changes to 0.
4. If the status of TRG is being Status 1 from the start, it can be regarded as the descending edge from the start.
5. TRG and R terminals are treated as Status 0 if they are set as X.
6. This function is applicable to the lighting of staircase, the control of barriers in a car park, the control of a water throttling valve, etc.

**3.2.4 TPBL**

Line diagram/ Symbol in SPR	Pin	Description
	<b>Input S</b>	Make the Output Q be Status 1 via Input S (Position).
	<b>Input R</b>	The Output Q is reset to 0 via R (Reset Input). If S and R are both Status 1, Output Q is 0. (R has a higher priority.)
	<b>Output Q</b>	When S is the Input, Q is connected and remained. It will be reset till R inputs the position.

**Switch Features:**

RS Relay is a simple trigger with two values. The output value is decided by the input status and the original output status. The following table can explain the logic relationship between them:

S	R	Q	Remarks
0	0		The status remain the original value.
0	1	0	Reset
1	0	1	Position
1	1	0	Reset (Reset has a higher priority)

Explanation: TRG and R terminals are treated as Status 0 if they are set as X.

### 3.2.5 BLNK

Line diagram/ Symbol in SPR	Pin	Description
	Input EN	Input (only be effective in high potential). Make the clock pulse generator connected or open via EN input.
	Input R	Make Output Q be 0 via Input R (Reset).
	Parameter T	Time parameter. T is the time length of output to be ON and OFF.
	Output Q	Every time EN changes from 0 to 1, the internal timer begins to time, and when Time T is up, the output is 1. If EN is held on 1, timing can be started again, and when Time T is up again, the output is 0. The cycle operation is continued in this way until EN is 0 and Output Q is 0. When R is 1, then the output Q is 0. And when R changes from 1 to 0 and EN is 1, all the initial status of Q changing from 0 to 1 will start its cycle.

Time Sequence Frame:

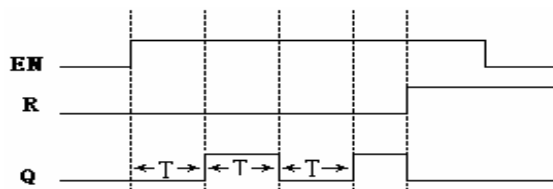

Function Description:

1. Use Parameter T to set ON/OFF time. The assignment range of T is 0.01-99.99 and the time units can be set respectively to hour (H), minute (M), second (S).
2. Input EN enables the clock pulse generator to work. Output Q of clock pulse generator will flip-flop the status every time the time T elapses, and cycle operation is continued in this way until Input En is 0. The clock pulse generator then stops operation and Output Q is 0.
3. EN and R terminals are treated as Status 0 if they are set as X.
4. This function is applicable to generate pulse automatically and to switch ON/OFF.

### 3.2.6 TMOD

Line diagram/ Symbol in SPR	Pin	Description
	<b>Input TRG</b>	Timer for ON time delay is started via Input TRG (Trigger).
	<b>Input R</b>	Timer for ON time delay is reset to ON via Input R, and make Output Q be 0). (The priority of R is higher than that of TRG.)
	<b>Parameter T</b>	After TRG is triggered and the time T elapses, the output is On.
	<b>Output Q</b>	After time delay T elapses, the output is ON.

#### Time Sequence Frame:

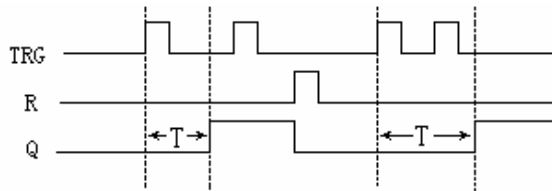

#### Function Description:

1. If the status of Input TRG changes from 0 to 1, the internal timer will be activated. When time T is up. Output Q becomes 1 and then the input TRG coming again has no effect on output Q. Only when Input R becomes 1 again Output Q and Timer T will be reset to 0.
2. TRG and R terminals are treated as Status 0 if they are set as X.
3. This function is applicable to the locations where the time-delay ON and hold ON status are required.
4. The assignment range for T is 0.01-99.99, and the time units can be set respectively to hour (H), minute (M), second (S). Its time accuracy can reach 0.5%.

### 3.2.7 PONS

Line diagram/ Symbol in SPR	Pin	Description
	<b>Input TRG</b>	Input TRG activated the single-pulse time and relay. When the descending edge is coming, it will output a pulse with the width of T.
	<b>Input R</b>	Reset Single-pulse time relay. When R is 1, the Output Q changes to 0.
	<b>Parameter T</b>	The assignment range of pulse width is 0.01-99.99.
	<b>Output Q</b>	Every time TRG changes from 0 to 1, the Q outputs a pulse with the width of T.

**Time Sequence Frame:**

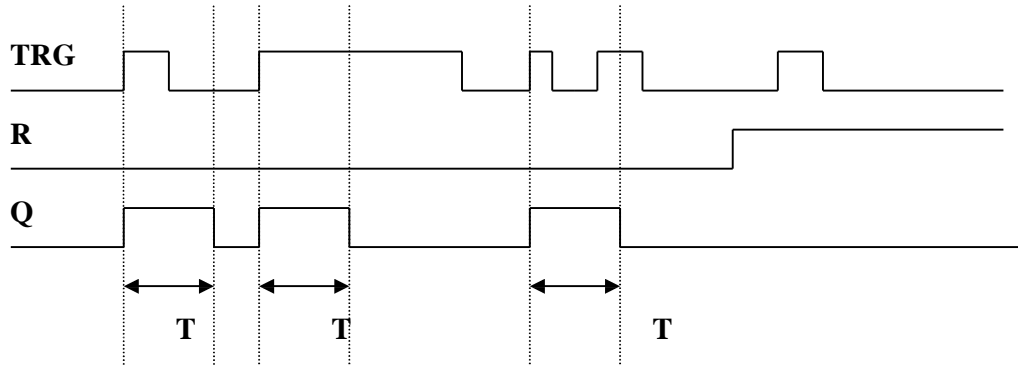

**Function Description:**

1. When Q is 1, TRG pulse has no effect on Output Q.
2. TRG and R terminals are treated as Status 0 if they are set as X.
3. This function is applicable to change the pulse width.

**3.2.8 UDCT**

Line diagram/ Symbol in SPR	Pin	Description
	Input R	Internal counter value and the output are reset via R (Reset). R has a priority to CTN.
	Input CNT	When CNT (Counter) is inputting, the counter just counts the change from Status 0 to Status 1 and doesn't count the change from Status 1 to Status 0.
	Input DIR	Appoint the direction of the counter via DIR (Direction) DIR=0; Adding Counting DIR=1; Minus Counting
	Parameter PAR	When the internal counter value is larger than or equal to PAR, the Output Q is 1. When the internal counter value is less than PAR, the Output Q is 0. The assignment range of the counting value is 0-999999.
	Output Q	When the counting value is arriving, the Output is on.

**Time Sequence Frame When PAR=5:**

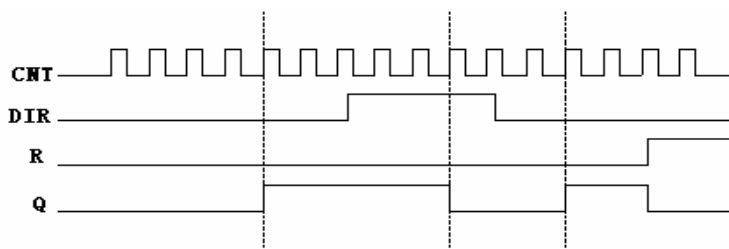

1. TRG and R terminals are treated as Status 0 if they are set as X.
2. Every time on Input CNT's descending edge, the internal counter adds 1

(DIR=0) or minus 1 (DIR=1). If the internal counter is larger than or equal to Parameter PAR, Output Q is set to 1. Reset can be used to reset the internal counter to 0. If R=1, Output Q is 1.

### 3.2.9 DOUT (need to select SPR-VP to use together)

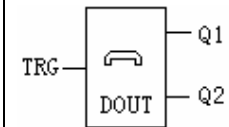
Line diagram/ Symbol in SPR	Pin	Description
	Input TRG	Selection for Input Port: I000~I127, Q000~Q127, HI, LO, M00~M99, N00~N99, P00~P99
	Output Q1	When TRG is high, it's time to dial out. After dialing successfully, the Q1 Port Output is high and Output Q2 is low. This state will remain till the TRG terminal is low and at that time Q1 and Q2 are simultaneously placed down.
	Output Q2	When TRG is high, it's time to dial out. If dialing unsuccessfully, the Q1 Port Output is low and Output Q2 is high. This state will remain till the TRG terminal is high and at that time Q1 and Q2 are simultaneously placed down.

#### Function Description:

The functions of telephone blocks are mainly dialing output alarming and so on. This block is used together with the locking-up relay (RS relay) function block. It can be used to not only receive the coming call signals to control the terminal equipment, but also dial to output under certain conditions. Presentation on how to implement it is made as follows.

This control requires the presetting of the telephone two-tone signal (P00-P99) to drive RS relay during the programming of SPR, the periphery devices is driven by the output of RS relay, so when SPR receives P00-P99 signals of an incoming call, it is possible to control the peripheral devices.

In the program, when the TRG pin of D\_OUT instruction was activated by an input, the voice module will dial the phone number which set in the D\_OUT instruction, if there is no answer from the telephone, the voice module will wait for the answer according the ring time which pre-set, if there is still no answer from the telephone after ringing for set times, then the voice will dial the telephone repeatedly according to the set dialing times. If there is answer from the dialed telephone then the voice module will play the voice messages as the following process.

1. If there was password, the voice module will play the No.01 message, user should enter the correct password, then will hear the set messages.
  - A. If the entered password is correct, the voice module will play the No.2 message, and will play the message which was set in the D\_OUT module repeatedly for 3 times, then the voice module will send a success signal bit to the SPR after 20 seconds, it means that the dialing is successful;
  - B. If the entered password is wrong, the voice module will play the NO.03 message, then play the No.01 message repeatedly, if the use enter wrong password for 3 times, the voice will stop playing and hang off the telephone. At this time, if all the dialing times was dialed, the voice will send a failure signal bit to the SPR. Or the voice will dial the telephone which was set in the D-OUT instruction, till finish dialing all the times or dial successfully, if the dialing failed for all the dialing times, the voice

will send a failure bit to the SPR, if the dialing is successful, voice module will send a success bit to SPR.

2. If there is no password item, the voice module will play the message which was set in the D\_OUT instruction for 3 times, then will hang off the dialing after 20 seconds delay, and send a successful bit to SPR.

When the user answer the telephone which was dialed by a voice module, if the user hang off the telephone, then the voice will finish to play the previous message, And will hang off after a few seconds delay.

**Note:**

1. The No.01, No.02, No.03 and No.04 messages are system message, and these messages can only be recorded into the voice module by users, and can not be played by D\_OUT instruction.

2. When the voice block are dialing a telephone number, if there is a password option, then only after the telephone was answered successfully and entered a correct password, then the voice will consider it as a successful dialing, and voice module will send a successful bit to SPR. Or, voice will consider it as a failure dialing, and will send a failure bit to SPR.

If there is no password item, then when the telephone was answered, then voice module will consider it as a successful dialing , after finishing to play the preset message, will send a successful bit to SPR. Otherwise , it will consider it as a failure dialing.

3. When you use the voice module, you must record messages firstly, and the system messages No.01, No.02, No.03 and No.04 have the following functions.

### **Telephone Alarm**

When the input of D\_OUT instruction was activated, it will start to dial the preset telephonenumber.

- **Telephone Alarm**

When the input of D\_OUT instruction was activated, it will start to dial the preset telephone number.

- **Automatic Dial and Automatic Alarm.**

**Note:**

When you edit the program by the front panel, the telephone number will be ended by a “: ”, the numbers behind “: ”will be forgotten, and “: ” is the end mark of telephone number. If there is no “: ”, then SPR will doesn't consider it is a full telephone number.

Please refer to Chapter VI to study the use of Voice module (SPR-VP).

### 3.2.10 D-IN (Need to purchase SPR-VP)

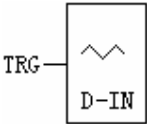
Line diagram/ Symbol in SPR	Pin	Description
 <p>The diagram shows a rectangular box labeled 'D-IN' with a zigzag line symbol inside. A line labeled 'TRG' enters the box from the left side.</p>	<p><b>TRG INPUT</b></p>	<p>When TRG become 1, will activate D_IN instruction, and will play the preset message</p>

**Function description:**

1. After D\_IN instruction was activated, , the voice module will start to play the preset messages in D\_IN instruction;
2. According to the different presetting in the D\_IN instruction, the voice module has the following applications:
  - (1). If there is only one D\_IN instruction in the user's program of the SPR:
    - A. If there is password protection, voice will play the No.01 message repeatedly, after the user enter the correct password, if the entered password is wrong, the voice will play the No.03 message, and then continue to play the No.01 message; if the entered password is correct, the voice module will play the No.02 message, and then play the preset alarm message which was set in the D\_IN instruction by user for 3 times, after playing 3 times, the voice will stop playing any message. Then will hang off the telephone automatically after 20 seconds delay, and go back to waiting status;
    - B. When there is no password protection for D\_IN instruction, voice module will play the preset message which was set in D\_IN instruction by user for 3 times, after finish playing, the voice module will stop to play any message, and will hang off the telephone after 20 seconds delay, and go back to waiting status;
  - (2) .When there are more than 1 D\_IN instructions in the user's program of SPR:
    - A. If all of the password protection of D\_IN was selected, the voice module Will play the No.01 message repeatedly, when the user enter the password, If the password is wrong, the voice module will play the No.03 message, And then will play the No.01 message repeatedly, if the entered password is correct, voice module will play the No.02 message, and then play the preset alarm message which was set in the D\_IN for 3 times, when it finish to play the 3 times, the voice module will stop playing any messages, and will hang off the telephone after 20 seconds delay. And go back to waiting status.
    - B. If there isn't any password protection for the D\_IN instruction, the voice module will play the alarm message which was preset in the D\_IN by user for 3 times, after 3 times playing, the voice module will stop playing any messages , and will hang off the telephone after 20 seconds delay, and then go back to waiting status;
    - C. If there is password protection for some D\_IN instructions, and some D\_IN instructions haven't password protection, then the voice module will play the preset alarm messages which was preset in the D\_IN instructions without password protection. After playing all the alarm message which haven't password protection, the voice module will play the No.01 message, after the user enter the password, if the entered password is wrong, the voice module will play the No.03 message, and will continue to play the No.01 message; if the entered password is correct, the voice module will play the No.02 message, then

the voice module will play the alarm messages which preset in the D\_IN instructions with password protection, after playing all the alarm messages for all D\_IN instructions, the voice module will start to play all the alarm messages for 2 times, at last the voice module will stop playing any message, and hang off after 20 seconds delay, and go back to waiting status;

3. When the user dial the telephone number which is connected to the voice module, and the D\_IN instruction wasn't activated, then voice will play the No.04 message to tell the user that there isn't any alarm.
4. When the user hear the voice module, if the user hang off the telephone, then the voice module will hang off the telephone automatically after a few seconds delay after playing the previous message.

**Note:**

1. The No.01, No.02, No.03 and No.04 message are system message, and cannot be played

in D\_IN instruction.!

2. User must record the messages firstly, then can use the voice module .No.01, No.02, No.03 and No.04 message must be record before using the voice module(Please refer the chapter VI to study Recording message of voice module)

### 3. 2. 11 PLAY (Need to purchase SPR-VP)

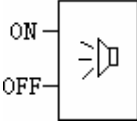
Line diagram/ Symbol in SPR	Pin	Description
	ON	When the ON input becomes 1, the voice module will play the message which preset in this instruction. The message input range of this instruction is from message 05 to message 98 (No.05 to No.98)
	OFF	When OFF input becomes 1, will stop playing the message. The input range is as following: I000~I127,Q000~Q127,HI,LO,M00~M99,N00~N99,X。

**Notes:**

- This function is applicable to location where voice prompt is needed.

### 3. 2. 12 CMPR

Line diagram/ Symbol in SPR	Pin	Description
	Input 1	Input 1 for comparing, can be selected as : 0.0~10.0V or I000~I127.
	Input 2	Comparing function, can be selected as • 、 • 、 〈、〉 、 =、 ≠
	Input 3	Input 2 for comparing, can be selected as : 0.0~10.0, I00~I127。
	Output Q	If the comparing condition between Input 1 and Input 2 is YES, Q will be 1, or Q will be 0, Q can be connected to 00~Q127,M00~M99,N00~N99。

**Function Description:**

Only SPR-12MRD, SPR-12MTD, SPR-22MRD, SPR-22MTD types have this function .

This function is used in the analogue input instructions.

**Using description:**

COMP instruction will compare the input 1 and input 3, when the input 2 was selected as “ <”, If the value of input 1 is larger than the value of input 3, the output will become “0”, if the value of input 1 is lower than the value of input 3, the output will become “1”, and so on.

**Example 1:**

Input 1 is connected to I001; Input 3 is 050;Input 2 is selected as “> ”

Output is connect to Q001

Then If the I001>5.0V, Q001 will become 1, and on the contrary, Q001 will become 0.

**Example 2:**

Input 1 is connected to I001, Input 3 is connected to I002,

Input 2 is selected as “ <”

Output is connected to Q001.

Then : if the real value of I001 is lower than the value of I002, then Q001 will become 1,or it will become 0.

**3.2.13 T/C-CMPR**

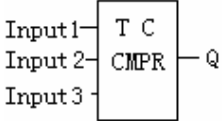
Line diagram/ Symbol in SPR	Pin	Description
	Input 1	The compared input 1, can be connected to an output of timer or a counter
	Input 2	Comparing function, can be selected as: • 、 • 、 <、 > 、 =、 ≠
	Input 3	The compared input 2, can be connected to an output of a timer or a counter
	Output Q	When the comparing condition is YES, the output Q will become 1, it can be connected to Q00~Q127,M00~M99,N00~N99.

**Function Description:**

This instruction can compare the value of timer or counter, the compared time range is 0.01~99.99 hour, and the counter range is 1~999999.

**Example 1:**

Input 1 is connected to a timer instruction, and the time unit is second,

Input 2 is selected as “> ”

Input 3 is 5 seconds

If input 1 > input 3, then the output Q will become 1, or it will become 0.

**Example 2:**

Input 1 is connected to a counter

Input 2 is selected as “> ”

Input 3 is 300

If input 1 > input 3, it means the value of input 1 is larger 300, then the out put Q will become 1, or it will become 0.

### 3.2.14 CW

SPR has clock switches for 127 time intervals.

Line diagram/ Symbol in SPR	Pin	Description
	Input ON	Set powering on of the time switch and select the model of the time switch.
	Input OFF	Set powering off time of the time switch. The model of the time switch is the same as which of the powering on time.
	Output Q	Output of the time model. If one set time interval is connected, the output is Status 1, otherwise it is Status 0.

The SCHD instruction is a very powerful tool of time switch, and it has 5 formats for selection:

Every year/ Every month/Every week/ Every day/ Day。

Some key points of SCHD:

1. In time switches, the set time should be according to the time schedule, such as (day style) :

ON time: AM 8:00 of May.1 2003  
 OFF time: PM 5:00 of May.1 2003  
 ON time: AM 9:00 of Oct.01 2003  
 OFF time: PM 7:00 of Oct. 01 2003

} Q1

The above of time sequence is correct, and the following is not correct:

ON time: AM 8:00 of May.02 2003  
 OFF time: AM 6:00 of May 01 2003  
 ON Time: PM 7:00 of Oct. 01 2003  
 OFF time: PM 3:00 of Oct. 01 2003

} Q1

2. In the SCHD instruction, if you set ON time and OFF time, then the output will be ON between the ON time and OFF time, the output will keep the previous status before the ON time, and will become OFF after the OFF time.
3. Regarding week style and day style, you can set ON time or OFF time. Its output will change as follows:

Preset Condition	Time	Output Status
Only ON Time Set	Before the ON Time	Keep the Previous Status
	At or After the ON Time	ON
Only OFF Time Set	Before the OFF Time	Keep the Previous Status
	At or After the OFF Time	OFF

4. Whichever function you selected of the Clock switch, you should list the time as the time sequence of the same day. For example:

Day style:

AM 8:00 May.01 2003 ON  
 AM 12:00 May.01 2003 OFF  
 PM 1:00 May. 01 2003 ON  
 PM 5:00 May. 01 2003 OFF

} This order is correct

Monthly style:

10:00 AM of Each June 01 ON  
 11:00 AM of each June 01 OFF  
 8:00 AM of each June 01 ON  
 9:00 AM of each June 01 OFF

This order is wrong, and the output will become OFF from 10:00 to 11:00

Week style:

Monday 9: 00 ON  
 11: 00 OFF  
 Monday 15: 00 ON  
 18: 00 OFF

This order is correct

Monday 9: 00 ON  
 11: 00 OFF  
 Monday 6: 30 ON  
 8: 30 OFF

This order is wrong, and the output will be OFF from 9:00 to 11:00

Note : This phenomenon is called last instruction priority proposal.

### 3.2.15 TSEQ( Time sequence)

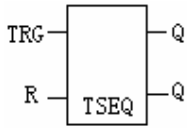
Line diagram/ Symbol in SPR	Pin	Description
	TRG Input	TRG is activated signal of this instruction.
	R Input	R is reset signal of this instruction, will let the output become 0.
	Q Output	Time sequence output, and it has 8 selectable outputs, it can offer 8 outputs status at the same time.

The function of the time sequence is as follows.

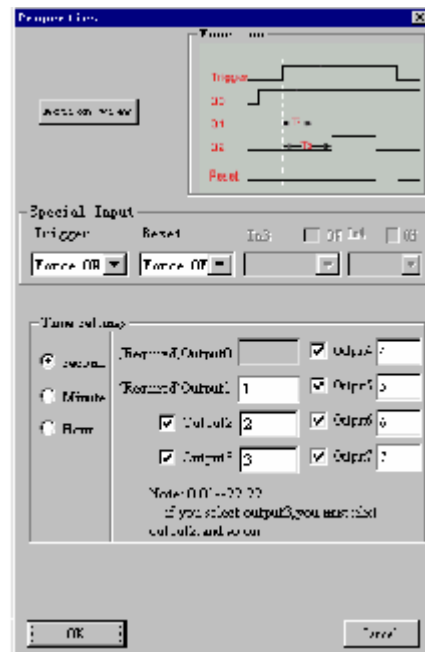

When you select a TSEQ instruction in the program, and double click it, it will display as above figure, you can select the output points, if you select Output 3,

output 2 will be selected automatically, the same way for output 4, output 5.....output 8. It means that if you select the behind one, then the previous one will be selected automatically. And you can set the output ON time, and the time unit can be selected as second, minute, hour.

In above figure, when the Trg become 1, then 8 outputs will become 1 one by one. It means: First second , OUTPUT1 become 1, the second second, OUTPUT2 will become 1, and so on, till the OUTPUT 8 become 1 in the eighth second, then it will stop. And the output loop will start again when there is a reset signal 1 was received on R.

**Note:** The first output 1 is fixed on 1 status, and need user to change it.

### 3.2.16 SSEQ (Step sequence)

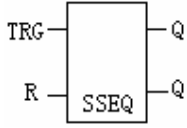
Line diagram/ Symbol in SPR	Pin	Description
	<b>TRG Input</b>	When TRG was activated, the SSEQ instruction will be activated.
	<b>R Input</b>	Reset signal will let the outputs become 0
	<b>Q Output</b>	There are 8 outputs can be selected, and this instruction can offer 8 status outputs.

The function of SSEQ is as follows:

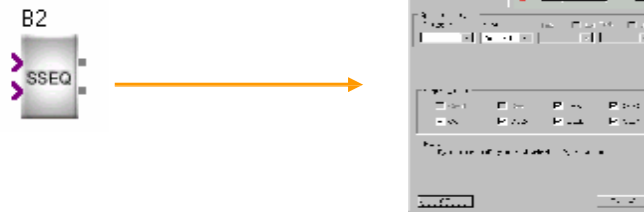

When you select a SSEQ instruction in the program, and double click it, it will display as above figure, you can select the output points, if you select Output 3, output 2 will be selected automatically, the same way for output 4, output 5.....output 8. It means that if you select the behind one, then the previous one will be selected automatically.

When TRG become 1 for one time, output 1 will become 1, and TRG become 1 for the second time, the output 2 will become 1, and so on, when there is a high potential on the TRG, the 8 outputs will become 1 one by one. Till output 8 become 1, and all outputs will become 0 after the next high potential on TRG. Then the loop will start again.

**Note:** OUT0、OUT1 is fixed on 1 , not be able to changed.

### 3.2.17 HOUR

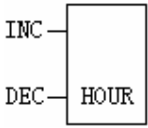
Line diagram/ Symbol in SPR	Pin	Description
	<b>Input INC</b>	<b>When INC was activated, the system time will increase 1 hour automatically.</b>
	<b>DEC Input</b>	<b>When DEC was activated, the system time will decrease 1 hour automatically.</b>

#### **Function Description:**

**When there is a high potential on INC, the system time will increase 1 hour automatically, when there is a high potential on DEC, the system time will decrease 1 hour automatically.**

## Chapter IV LCD Screen message

### 4.1 The difference between LCD message of SPR and the traditional LCD message

In the use of traditional LCD messages, it can only display some fixed message screen such as time, I/O status etc, it can not display the counter value, timer value and analogue value. And all the LCD message screens is set and programmed by the program engineer, so users can not change, add, or remove any message screen. And the operation of the traditional LCD message screen is not easy to use for the end user.

Regarding the above shortcomings of the traditional LCD screen message, we have adopted a new method to develop the SPR, and offer to user a free, and easily LCD instruction, the powerful function of the LCD( Can be called HMI) is as follows:

1. There are total 64 message screens at the most, user can edit each message screen. And the alarm message screens will be display automatically when it was activated by program. And other message screen can be displayed on the LCD by page up and page down by hand.

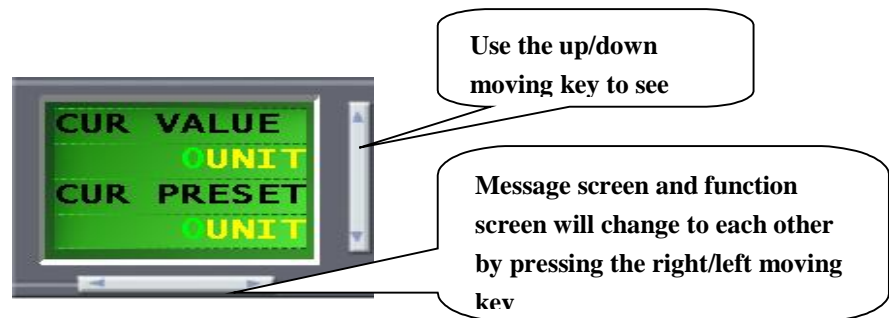

2. It offer to user a lot of kinds of message screen, when you want to edit a message screen, the system will create a referring message screen according to the connection relation, so user just need to make some minor changes on the message screen, for example as follows:

Note: B0 block is a CMPR instruction, and it has a screen message as L:0, connect the under output leg of B0 to the under leg of L:0,



Double click the L:0, it will create the following left screen.

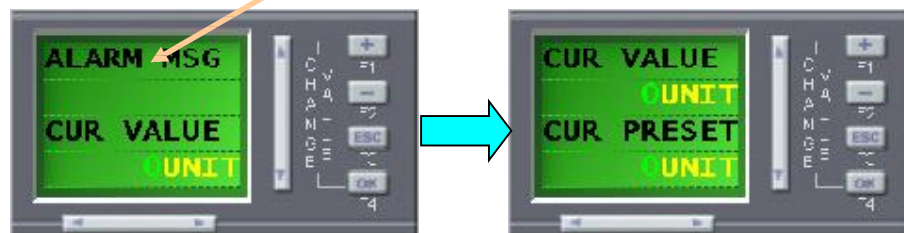

Created screen automatically

After minor change

3. The LCD message screens have very clear and understandable connection to instructions. User only need to link the message screen to its instruction, then all the

message in this message screen will be related to the connected instruction. For example as follows:

Note: Set the parameter of B0 as follows:

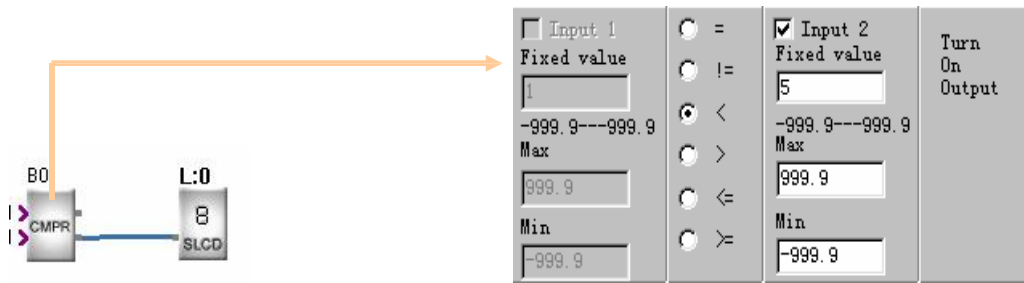

The LCD will display the real value and preset value of B0.

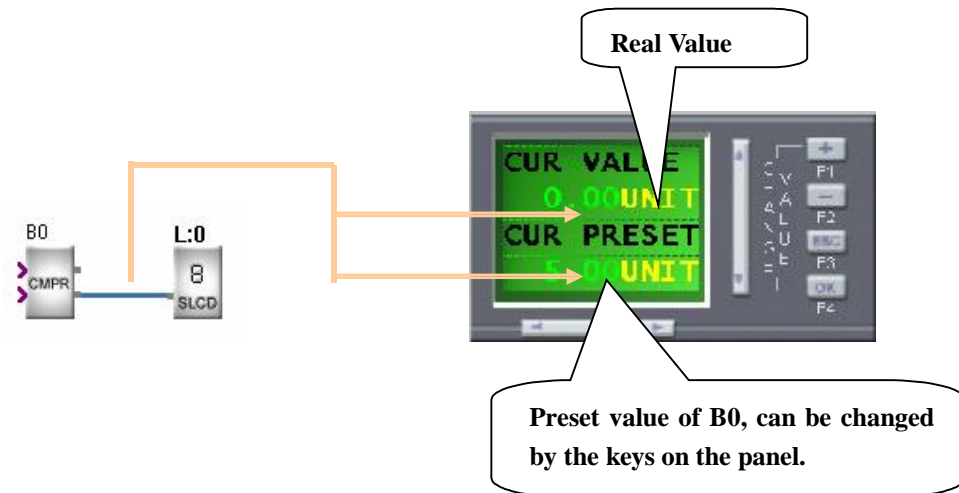

4. Activating alarm message function. When the output of the previous instruction is status 1, it can activate the linked alarm message screen(L0), and the alarm message will be displayed to user.

The work is as follows:

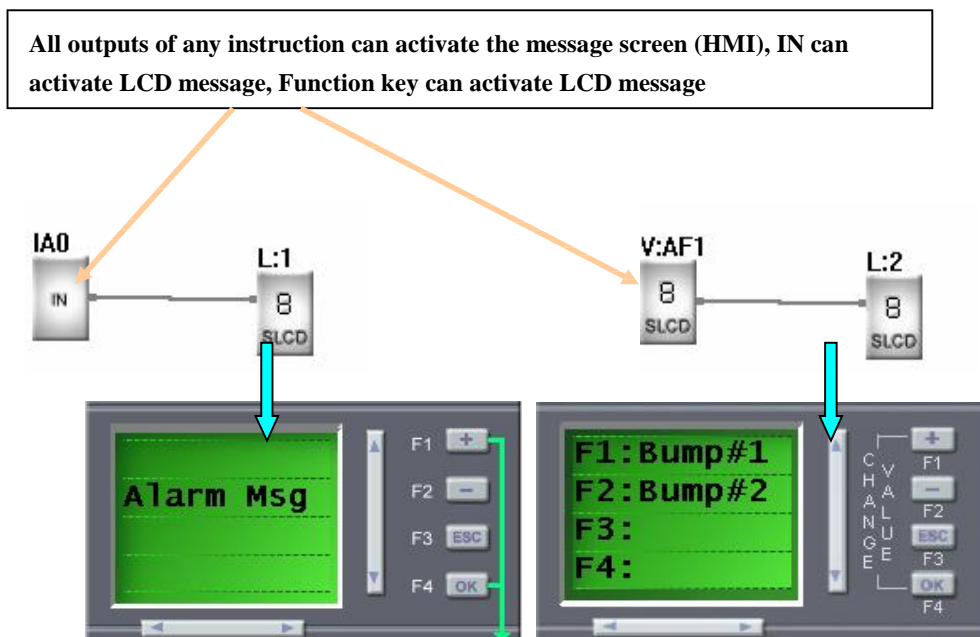

All outputs of any instruction can activate the message screen (HMI) Output of CMPR can activate LCD message, IN can activate LCD message

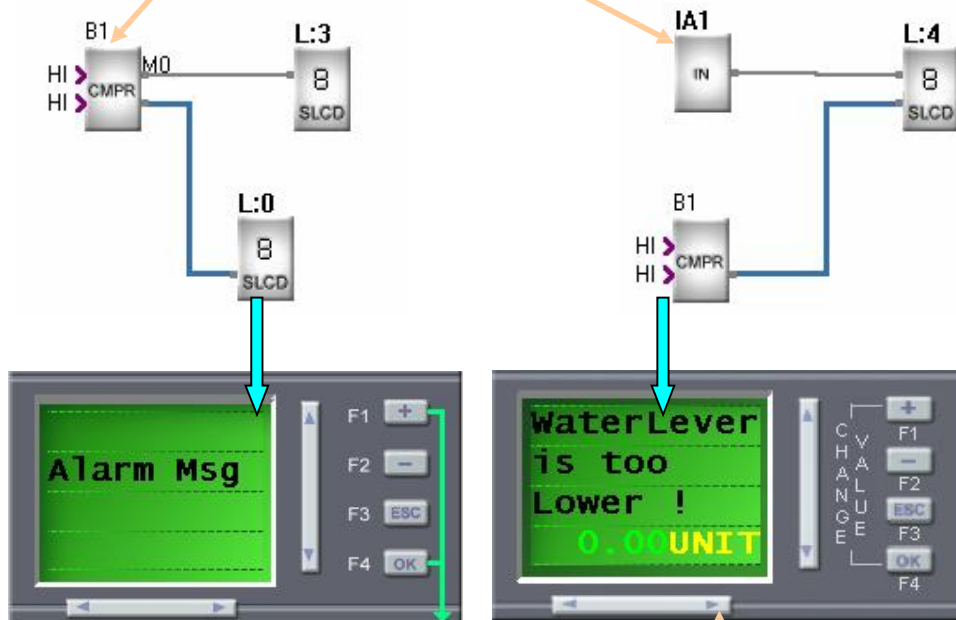

When IA1 become 1 status, then the LCD will display the alarm message and indicate the water level value.

5. There are total 32 function keys can be used in the SPR product, each function key can work as a INPUT (I0-In), its function is as the same as a soft switch, and there are 8 page screens at the most to realize the 32 function keys function, and each page can offer 4 function keys as F1, F2, F3, F4, from the LCD, you can see the definition and password protection of each function key.



6. We can order message screen pages very easily. When you edit a lot of LCD message screens, and they have the different priority, so we can use order them according to its priority, the more important one should be displayed more previous than the not important one by their sequence, and you can use the page up and page down to view all the message pages. See the following figure, and you can click each message screen, and move it to any place.

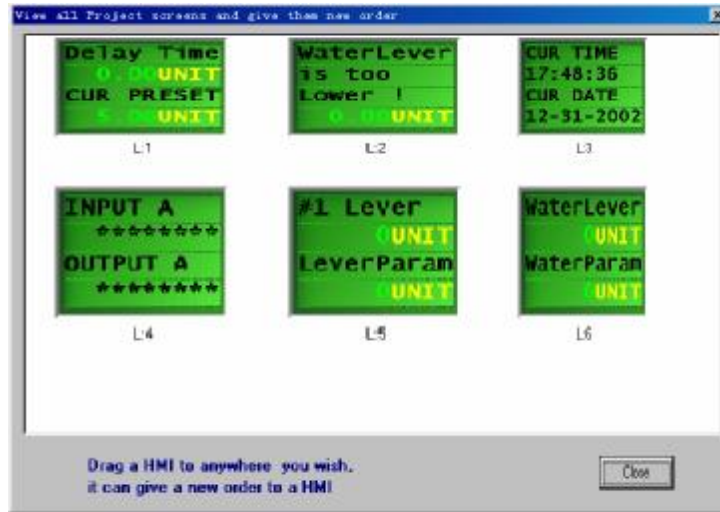

7. The HMI offer the special characters, and there are fixed special characters in the LCD, these characters can represent some standard AscII code, you can select these special characters when you can not type them in the windows system. It is very easy to use for the user. There are following special characters in its software.



#### 4.2 LCD message screen application example

*Note:* This is a water supply system.

1. The water supply system diagram is as follows:

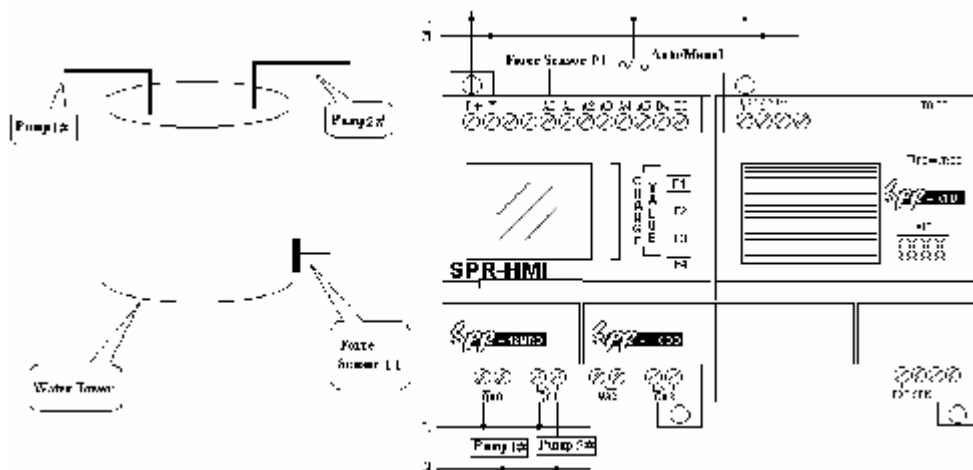

#### 2. Description

a. We use a SPR-12MRD to compare the Pressure 1 and 7V, if  $P1 < 7v$ , then start the pump #1; if  $P1 < 3v$ , then start the pump #2; if  $P1 < 1v$  for more than 5 minutes, then start the voice alarm. Connect P1 to I0(I0—I7) are analog input)

b. SA is a Manual/Auto switch, connected to I4 and I5.

c. when you choose SA as manual operation, there are two function keys in the

program, V:AF1 will control the pump #1, and V:AF2 will control pump #2.  
d. when you choose SA as Auto operation, the pressure comparing instructions B0,B1 and B6 will work, the parameters of B0,B1 and B6 are as follows:

<input type="checkbox"/> Input 1	<input type="radio"/> =	<input checked="" type="checkbox"/> Input 2	Turn On Output
Fixed value	<input type="radio"/> !=	Fixed value	
1	<input type="radio"/> <	71	
-999.9---999.9	<input type="radio"/> >	-999.9---999.9	
Max	<input type="radio"/> <=	Max	
999.9	<input type="radio"/> >=	999.9	
Min		Min	
-999.9		-999.9	

B0

<input type="checkbox"/> Input 1	<input type="radio"/> =	<input checked="" type="checkbox"/> Input 2	Turn On Output
Fixed value	<input type="radio"/> !=	Fixed value	
1	<input type="radio"/> <	3	
-999.9---999.9	<input type="radio"/> >	-999.9---999.9	
Max	<input type="radio"/> <=	Max	
999.9	<input type="radio"/> >=	999.9	
Min		Min	
-999.9		-999.9	

B1

<input type="checkbox"/> Input 1	<input type="radio"/> =	<input checked="" type="checkbox"/> Input 2	Turn On Output
Fixed value	<input type="radio"/> !=	Fixed value	
1	<input type="radio"/> <	1	
-999.9---999.9	<input type="radio"/> >	-999.9---999.9	
Max	<input type="radio"/> <=	Max	
999.9	<input type="radio"/> >=	999.9	
Min		Min	
-999.9		-999.9	

B6

B0 will control the pump #1, B1 will control the pump #2, B6 will control the voice alarm message to alarm.

e. The logic control program is as follows:

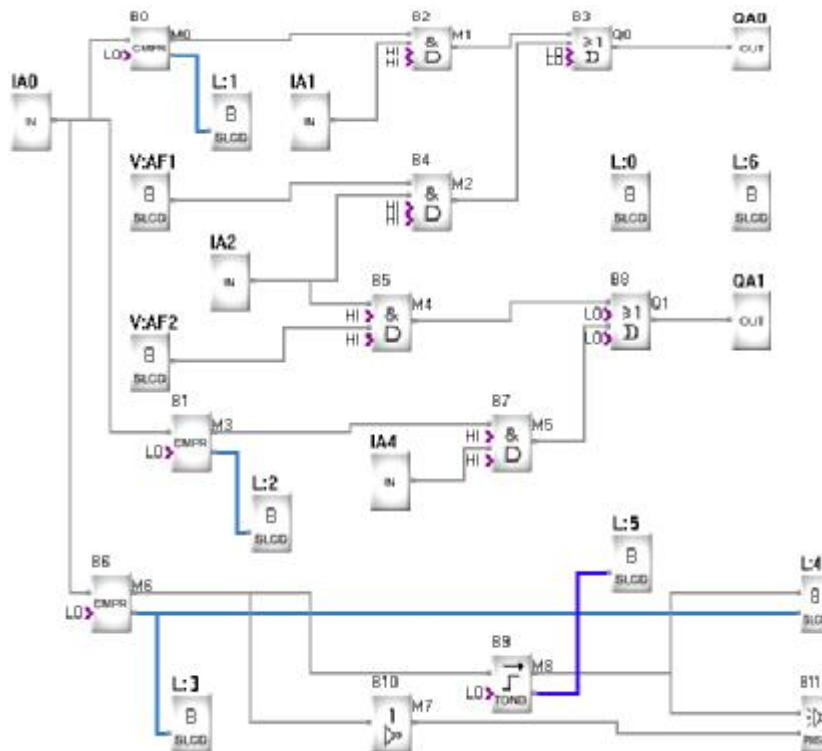

f. Edit the LCD message screen. There are total 7 message screens in this example, describe as follows:

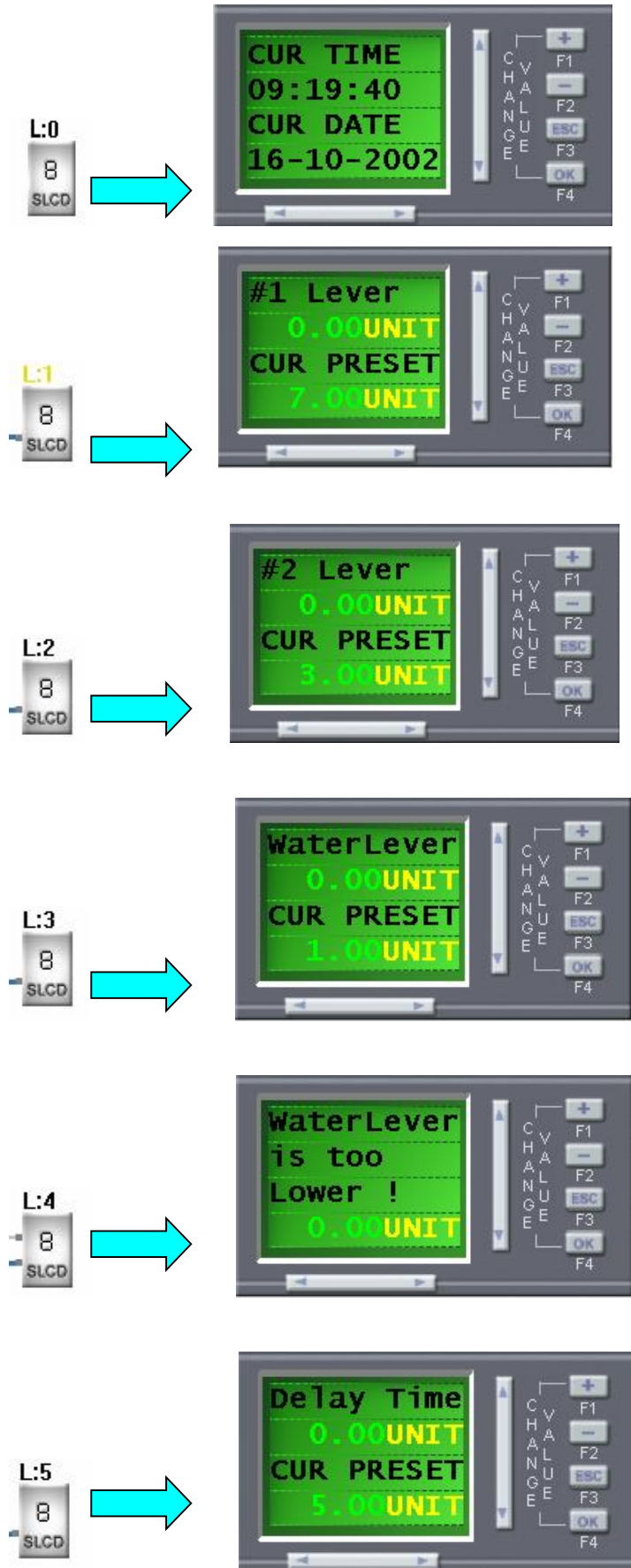



### 4.3 Edit the message screens

 **Note:**

*There is a LCD display on the hardware of SPR, and the LCD can display the system messages, alarm messages, RUN/STOP status, I/O status, parameter changes and function keys. All the messages can be edited by users according to his requirements.*

LCD message screen can be divided into 3 types:

- a. System message: display system time, I/O status, and function keys.
- b. Parameter message: display the value and pre-set parameter of Counter, timer and a Analog
- c. Alarm message: the alarm message which will be displayed on the LCD after activated.

1) Edit the system message:

Start to edit a control program by the Super Relay Logic software, to create a new file as follows:

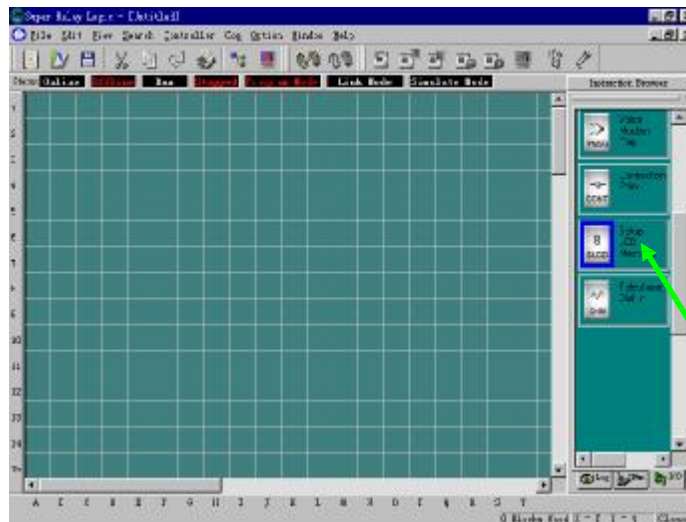

Choose the SLCD, and put it to the edit window, a SLCD set up window will appear as follows:

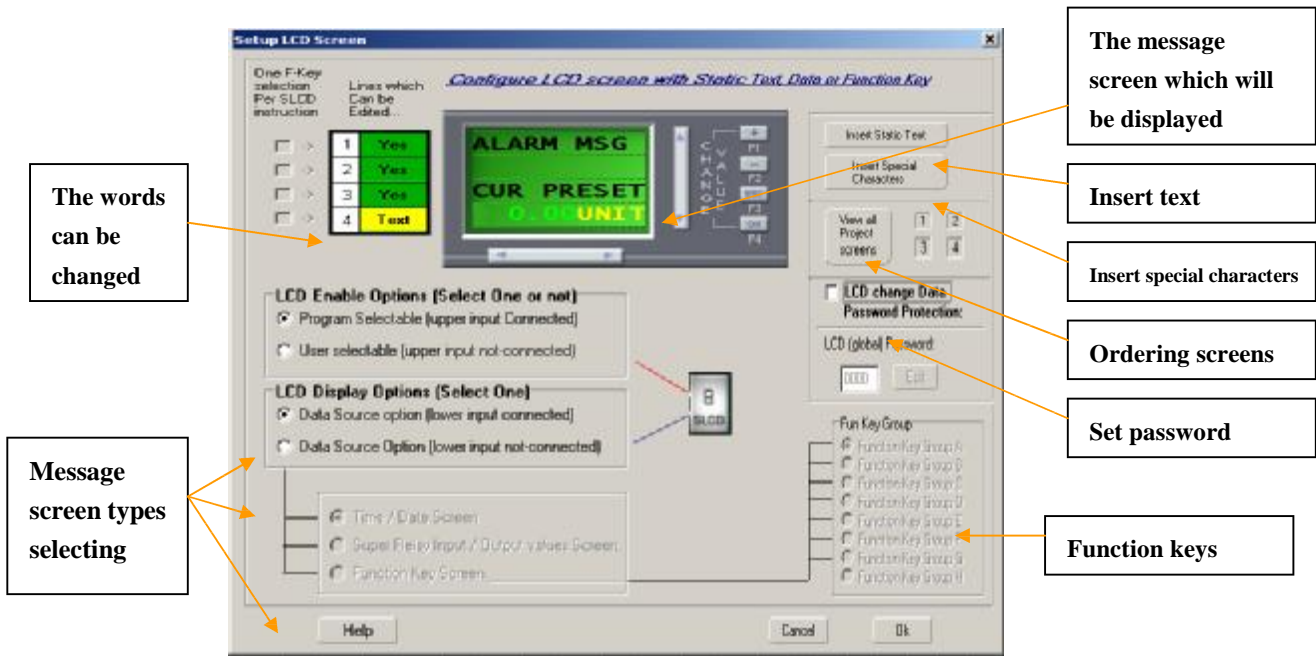

①. Edit a system time message screen in the program, the operation is as follows:  
 Take a SLCD instruction to the edit window as the following figure:

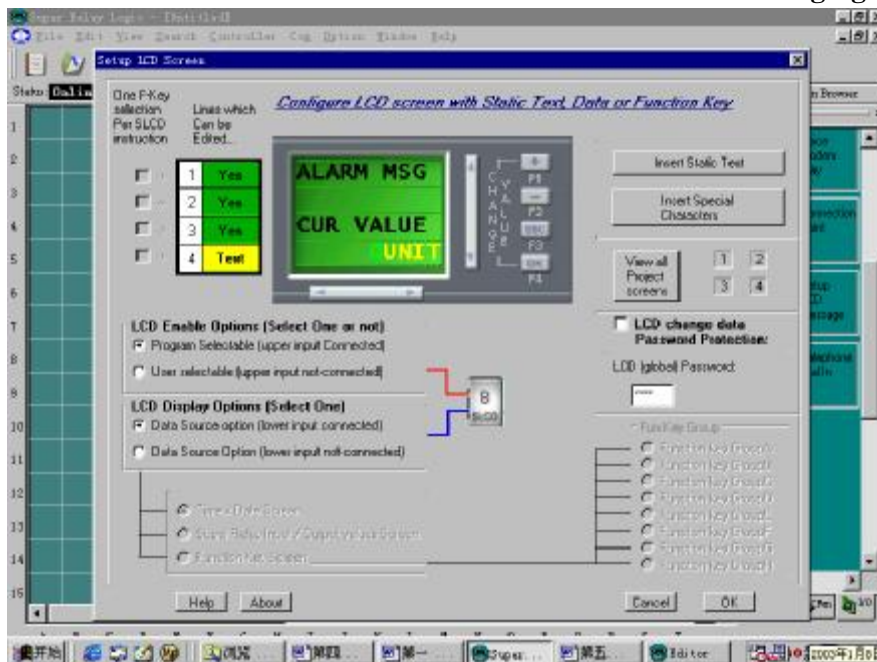

Choose “User selectable (Upper input not connected)”  
 And choose “Data Source Option (Lower input not connected)”

And choose “Time/Date Screen”, then the message screen will appear as follows:



The words on the green lines can be changed

Double Click to Modify

Double click “CUR TIME” or “CUR DATE” to modify them as you wanted.

Double click “CUR TIME” to enter the modifying dialog box as follows:



Type “TIME IS:”, and press “Enter”, the modified words description is as follows:



Click “OK” to finish the setting of the time/Date. In run status, the second line will indicate the real time, and the fourth line will indicate the Year/Month/Date.

## ② I/O status message screen

Take a SLCD instruction to the edit window and choose the selectable items as follows:

Choose “User selectable (Upper input not connected)” And choose “Data Source Option (Lower input not connected)” And choose “Super Relay Input/Output values Screen”, the message screen will appear as follows:

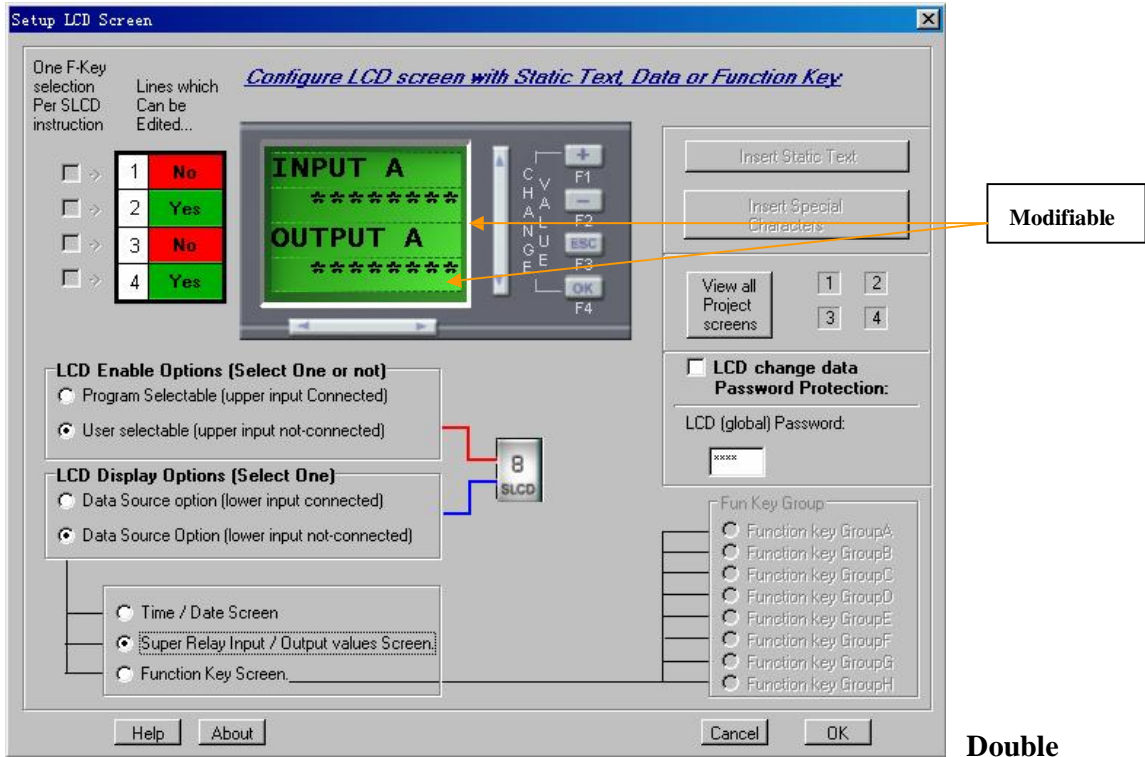

click , to choose the group of I/O, see following figure:

We divided the I/O into 8 groups, because the SPR I/O can be extended to 74I/48O, and each LCD line can only display 10 points at the most.

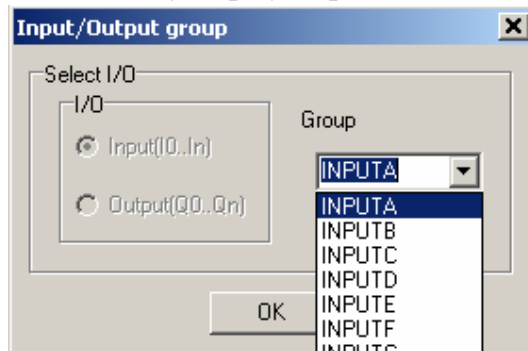

Select INPUTB, the modified message screen will appear as follows:

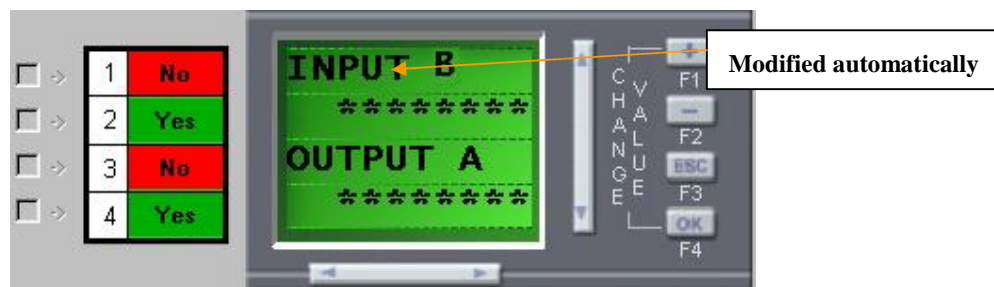

③ Edit a alarm message screen.

Alarm messages screen will be activated by a connected instruction, when the condition is satisfied, the alarm message will appear on the LCD:

There are 2 kinds of alarm message screens, the relative selectable items are as

following two figures:

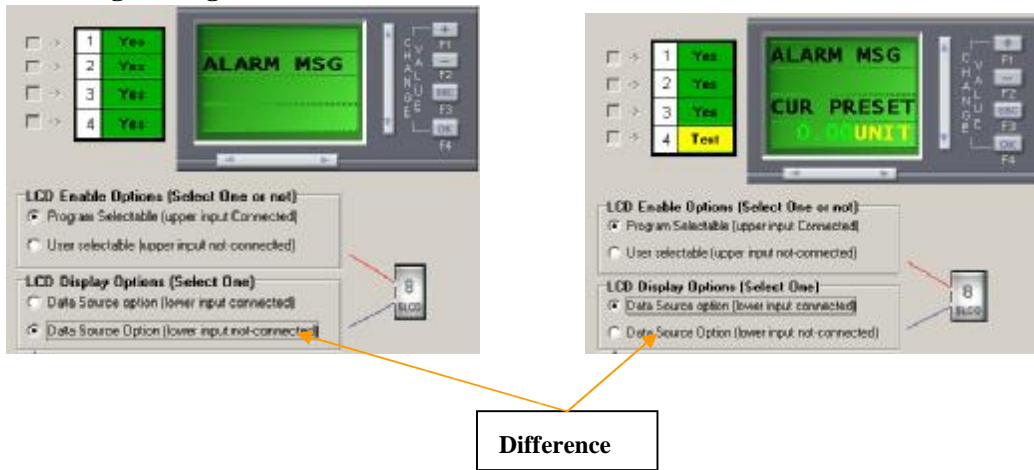

On the other hand, their link mode is not the same, they are as follows two figure:

a. Will not display the current value:



b. Will display the current value



OR



The related instructions are: TOND, TOFD, SPBL, BLNK, TMOD, UDCT, PONS, CMPR, CT CMPR.

④ Edit a parameter message screen.

User can change the preset of the parameter on this kind of message screen by the panel keys on the SPR.

Take a SLCD instruction to the edit window and choose the selectable items as follows:

Choose “User selectable (Upper input not connected)”

And choose “Data Source Option (Lower input connected)”

The dialogue box is as follows:

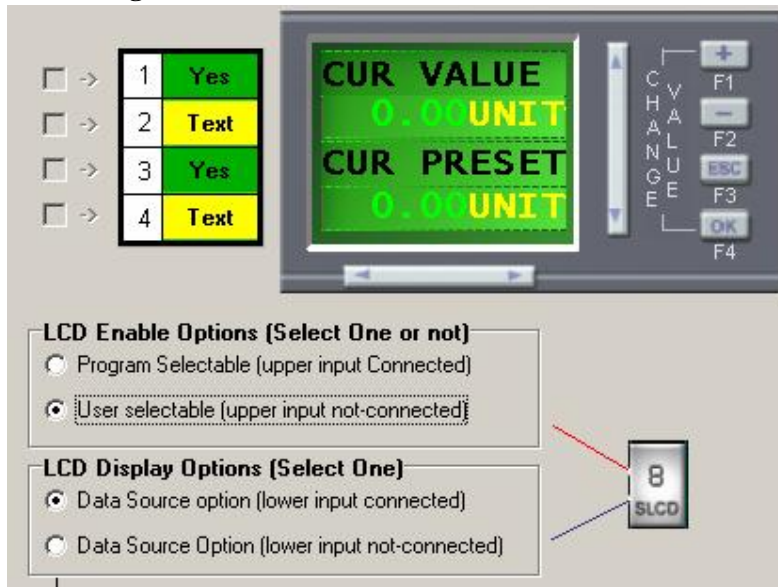

This message screen will display two values, one is current value, and the other is preset value.

User can change the description words on each line of the LCD screen.

The related connected instructions are: TOND, TOFD, SPBL, BLNK, TMOD, UDCT, PONS, CMPR, CT CMPR.

Note:

TOND, TOFD, SPBL, BLNK, TMOD, UDCT, PONS, CMPR, CT CMPR can have two different message screens such as following program:

L:6 displays the parameter setup, L:3 displays the alarming information.

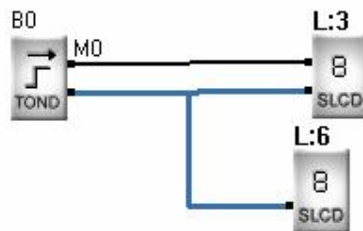

There are 2 kinds of set method for presetting the value of CMPR:

1) One kind is that it only has 1 leg need to be compared (including two conditions):

(1) upper leg connected to an input for comparing to a fixed value, see following figure.

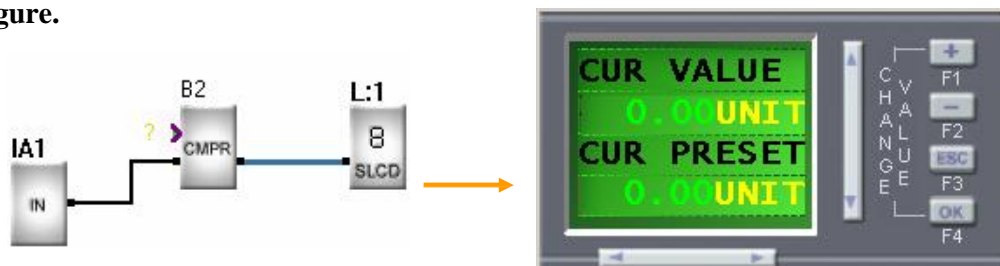

(2) Lower leg connected to an input for comparing to a fixed value, see following figure

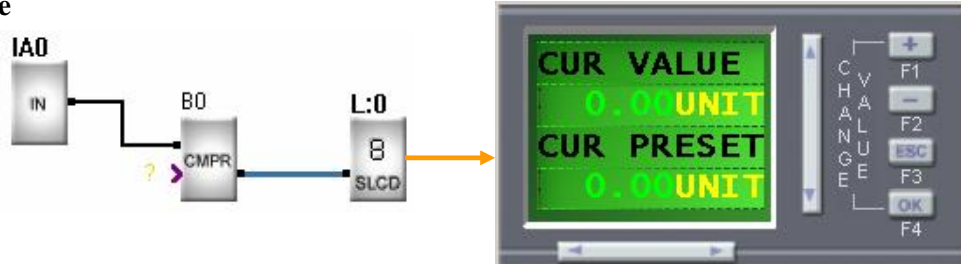

2) two leg are connected to inputs for comparing each other

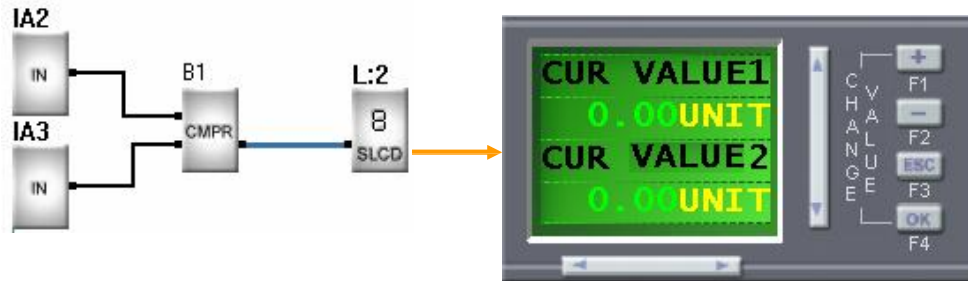

⑤ Order message screens

When you edited a lot of message screens, you need to order them and let the more important one be displayed more previously. You just need to click and move any screen to the wanted place, the ordering dialogue box will appear as follows:

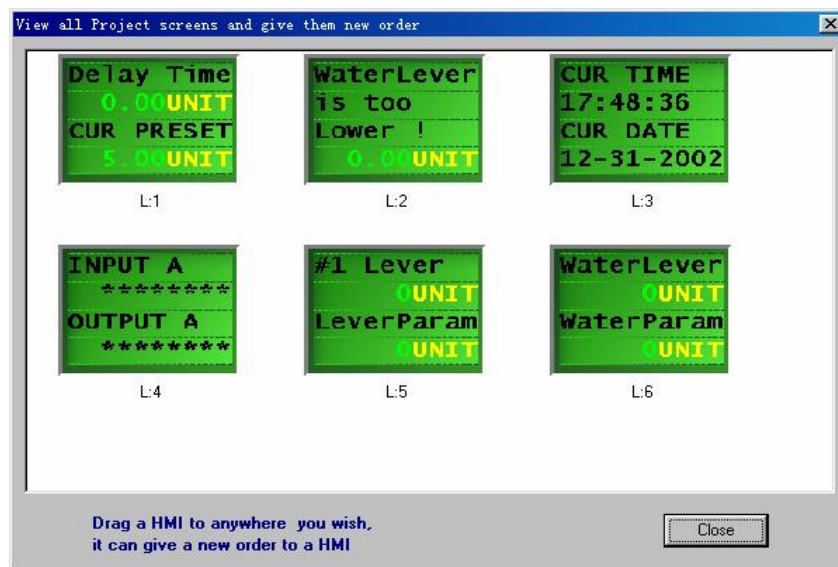

User can move each message screen to any place by clicking and moving it, such as place L:2 to the first place, just need to click and move L:2 to the place of L:1, then L:1 will go to the second place automatically, it is very easy to use.



#### 4.4 Fkey Operation

In the Super Relay Logic software, we have defined 32 function keys in 8 pages (A,B,C,D,E,F,G,H), each page has 4 function keys (F1—F4), when a function key was activated, it will offer a high or low potential (1 or 0 status) output, and this output can be used as an input for any other instructions to act as a switch function. User can select the function key group from group A to group H, and then select a key from F1 to F4 in the following figure:

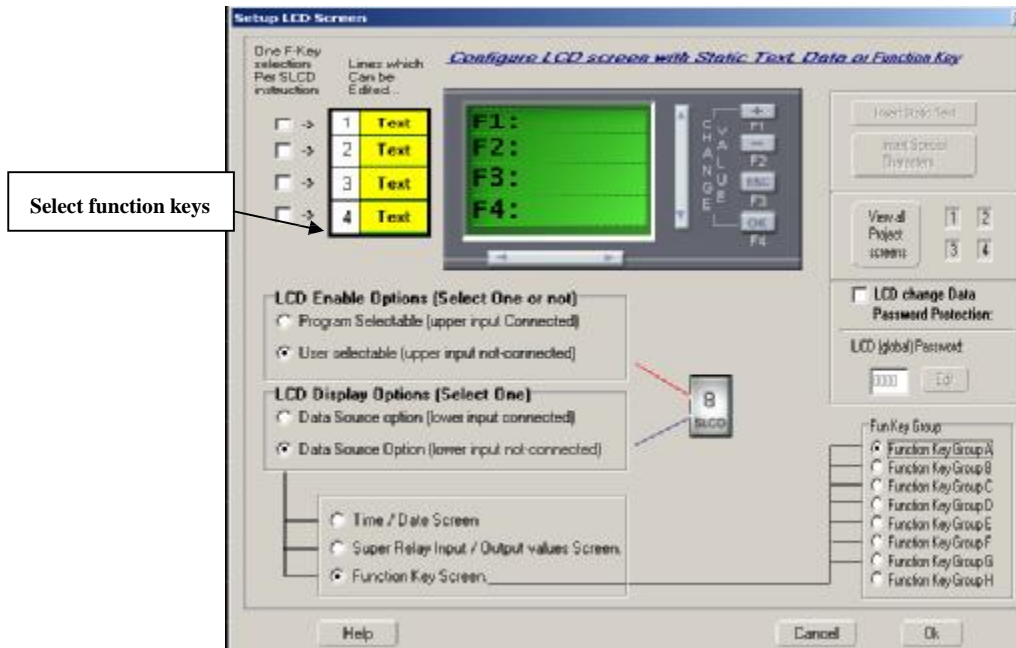

After selected the selectable items, the following dialogue box will appear, and you can name the function key(or give some description for the function key), and you can set the password protection for the function key. At last, click OK to finish the definition of a function.

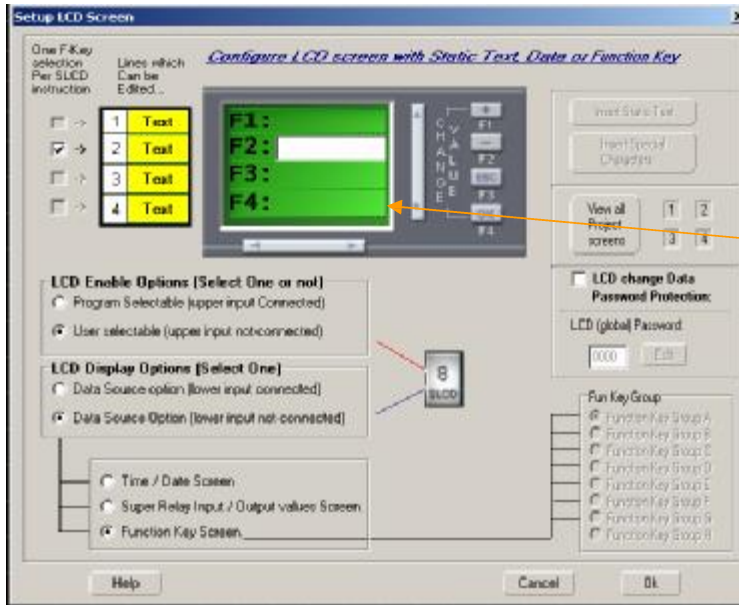

Enter the description of the function key (7 characters at the most)

Such as typing “Run fan” into the blank of , and press “Enter” to finish the setting. It will display as:



If you want to modify the description, just need to double click “F2: Run fan”, then type the new words in the blank of , and then press “Enter”. Then press “OK”, the function will displayed in the edit window as follows:



The function can be acted as an input to any other instructions. Such as:

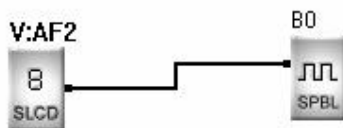

#### 4.5 Set password

There is a password protection option in SLCD dialogue box, you can choose according to your need.

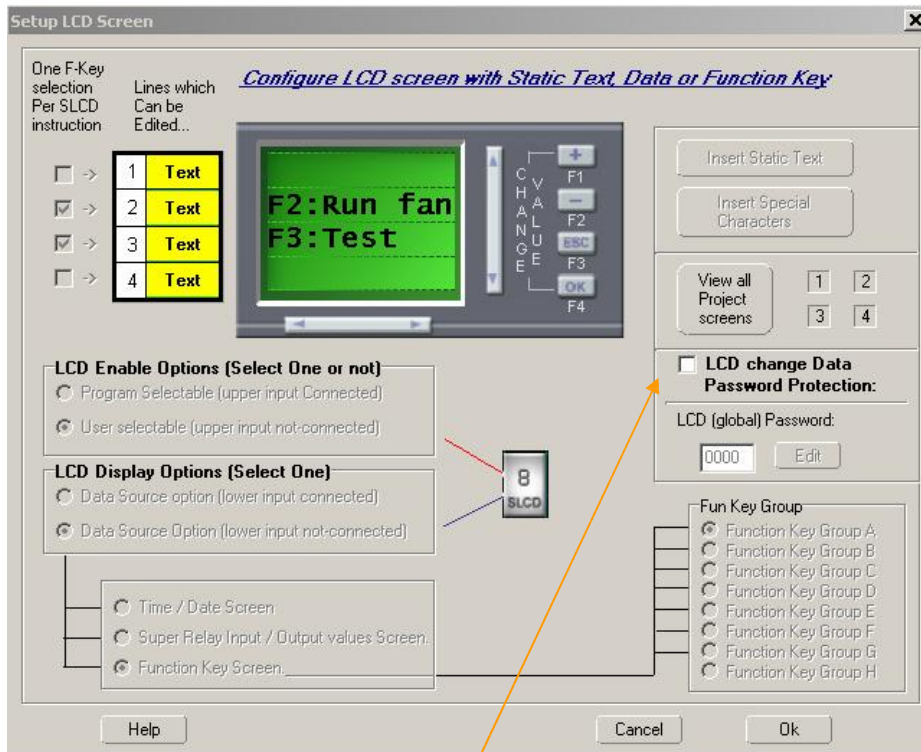

Click and choose “LCD change Data password protection”, and “Edit” will be activated, you can change a new password.



Click “Edit” , enter the 4 Characters password(0—9), then press “Enter” to confirm, see following figure.



#### 4.6 The use of LCD screen Help

There is a “Help” button in the dialogue box of Setup LCD Screen , click to select the help function, the following figure will appear.

**LCD Screen Help** [X]

*LCD Screen Enabled Options*

- Program Selectable Enable(Connected)  
 In the Configuration, the user program enables the LCD display  
 Instruction by connecting the enable input(upper input)



- User Selectable Enable(Unconnected)  
 In the Configuration, the user enables the LCD display Instructions by  
 Scrolling through the user selectable LCD Instructions with the LCD Keypad



*LCD Screen Options*

- LCD Simple Static test message Only(no data displayed)
- LCD Value input(Lower Input Connected)  
 Display the Current Value and Preset  
 Time off dealy,Counter,Blinker,  
 Compare,Time Sequence, or  
 Step Sequence instruction

- LCD Value input(Lower Input not-Connected)  
 In this Configuration, nothing is Connected to the LCD Data input(bottom)  
 The user will still have the option of displaying three 'system' Screens from  
 The 'LCD Screen Editor' (password, time/date & Super Relay input/output values)

- Function Key Screen  
 A possible total of 32 function Keys:  
 Four function Keys(F1-F4) can be  
 assigned to 8 different Groups(A-H).  
 Note: one functionkey pers LCD instruction



Retrun

**User can use this help function to view and study all the function and operation of the SLCD.**

## Chapter V Voice Module

Voice alarm function, telephone control function and dialing automatically function are very important functions of SPR. To realize these functions, we should match SPR with the SPR-VP voice module. Voice module blocks have two types: SPR-VPA (AC Type), SPR-VPD (DC Type).

### 5.1 Structure of Voice Module

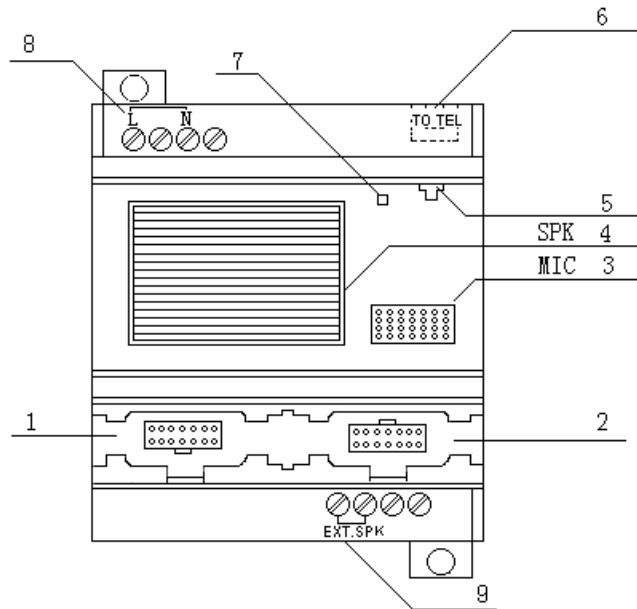

Fig. 5.1 Structure of SPR-VP Series Voice Module

1. Connecting port between voice module and the machine
  2. Connecting port between voice module and communication cable
  3. MIC (Users may record through this place when recording off-line or through the front panel.)
  4. SPR (Speaker broadcasting interface which the voice module self-carrying)
  5. Voice module on-line recording audio input port
  6. Socket of telephone crystal plug
  7. Indicator of the power and recording of the voice module (It will be on green when the voice module is powered on-power indicator. It will be on red when the voice module begins recording-recording indicator. When recording, users must wait till the recording indicator is lighted and stop when it is off. Otherwise the voice can't be recorded.)
  8. Power input (AC or DC) (100-240VAC), (12-24VDC)
- Audio output port (to be connected with the acoustics)

### 5.2 Connection between Voice Module and SPR

SPR-VP type voice module can be connected with the SPR series machines through SPR-CB. Pay attention that only the machines of the same type can be connected together. That is to say that SPR-VPA, AC type, can only be connected with AC type machine and SPR-VPD, DC type, can only be connected with DC type machine. Insert the telephone crystal head into the "TO TEL" socket. Insert one head of the audio wire into the audio input port of the voice module (5 of Fig. 5.1) and connect

the other head with the audio output of the PC. And connect the voice module and PC by the SPR-CP.

**1. Connection between SPR-12MRA and SPR-VPA (AC type)**

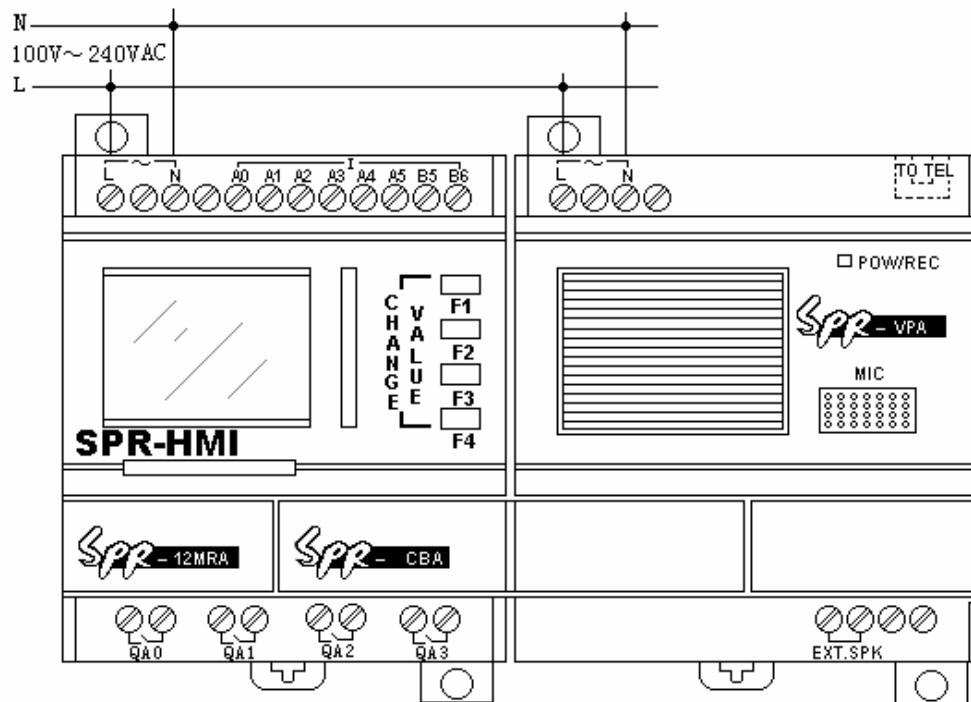

**Fig. 5.2 Connection between SPR-12MRA and SPR-VPA**

**2. Connection between SPR-12MRD and SPR-VPD (DC type)**

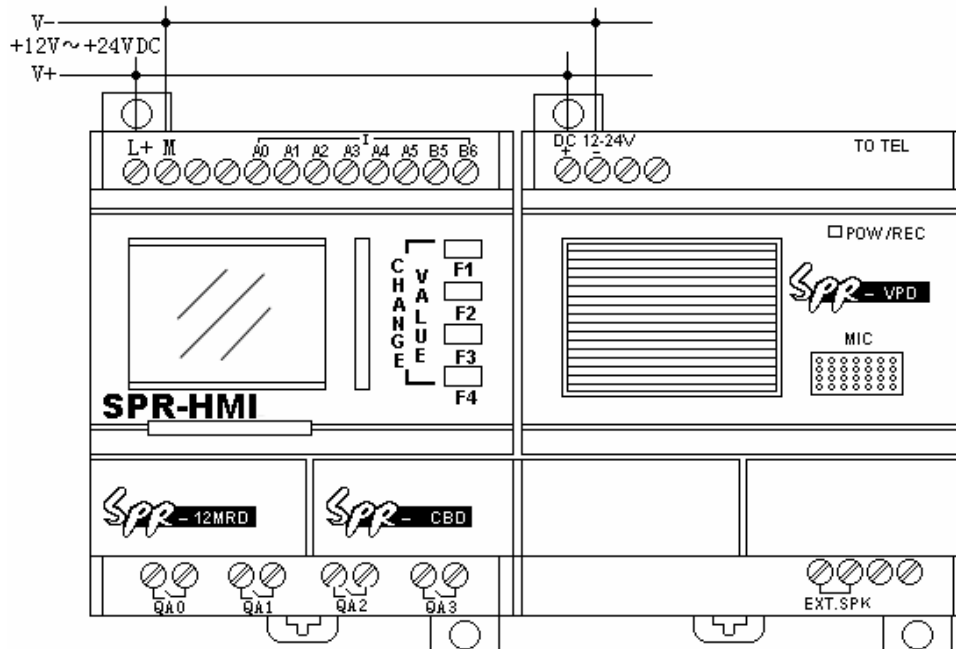

**Fig. 5.3 Connection between SPR-12MRD and SPR-VPD**

---

 **Notes:**

- 1. Telephone wire is two-core wire.**
  - 2. Insert the telephone crystal head into the “TO TEL” socket.**
  - 3. Remote control module can be flying connected with voice module to realize the wireless control to the voice module.**
- 

### **5.3 Operation Instruction of the Voice Module**

- 1. The first five Messages (Message 0, Message 1, Message 2, Message 3, Message 4) are for the voice system, users cannot record the five Messages randomly.**
- 2. Message 5 to Message 99 of the voice module are the voice Messages when users programming and can be used randomly. However, users must start recording from Message 0 while the functions of Message 0 to Message 4 are fixed by the system.**

**Functions from Message 0 to Message 4 are as shown in the follows:**

**Message 0:** When dialing out through the “D\_OUT” module, it will broadcast this Message “Please enter No. 0 key and receive the information”. (When recording, users must record this voice contents “Please enter No. 0 key and receive the information”).)

**Message 1:** is the prompt voice for confirming the user status. It will be broadcast when SPR system number has been dialed. Normal broadcasting can be carried out with this Message.

**Message 2:** is the prompt voice for the correct password. It will be broadcast when the correct password is used. Normal broadcasting can be carried out with this Message.

**Message 3:** is the prompt voice for the wrong password. It will be broadcast when the wrong password is used. Normal broadcasting can be carried out with this Message.

**Message 4:** is the prompt voice for dialing to an external telephone. It will be broadcast when SPR dials an external telephone. Normal broadcasting can be carried out with this Message.

### **3. Usage of the five special Messages**

**For example: users can use the five message Messages as follows:**

#### **Step I:**

**Record Message 0 as Please enter No. 0 key and receive the information.**

**Record Message 1 as Please enter the password for confirmation.**

**Record Message 2 as Correct password. Please enter the control code to control.**

**Record Message 3 as Wrong password. Please re-enter.**

**Record Message 4 as Emergency. Please enter the password to control.**

**Record Message 5 as Emergency. Gas leakage.**

#### **Step II:**

**When a user dials external telephone, SPR will answer the telephone automatically and broadcast-Please enter the password for confirmation, then the user enter the SPR password.**

- A. If the entered password is correct, SPR will then broadcast-Correct password. Please enter the control code to control. Then the user can control the equipment by the use of the telephone.**

- B. If the entered password is not correct, the SPR will broadcast-Wrong password. Please re-enter. Then the system will repeatedly broadcast-Please enter the password for confirmation.**

**Step III:**

When SPR dials an external telephone number, it will broadcast the pre-set message such as Message 5-Emergency. Gas leakage. Together with Message 4-Emergency. Please enter the password to control.

- A. When the user enters the correct password, the voice system will broadcast Message 2-Correct password. Please enter the control code to control and then repeatedly broadcast Message 5-Emergency. Gas leakage. At this time the user can real-time control the equipment by the use of the telephone.**
- B. When the user enters a wrong password, the voice system will broadcast Message 3-Wrong password. Please re-enter. And then it will broadcast Message 4 and Message 5 repeatedly.**



**Notes:**

- 1. SPR dialing an external telephone, if there is no answer or a password is not input within 40 seconds of the connection, the SPR voice system will stop dialing and cease to broadcast the voice message. The SPR voice system will then redial automatically every 40 seconds.*
- 2. User must enter a \* before entering the password. The broadcasting will then stop and the user should enter a four-digit password within 9 seconds. If the user fails to enter the password, the SPR voice system will rebroadcast the prompt voice. The user must then enter \* first and then enter the password, if the user needs to enter the password again the procedure needs to be repeated. That is to say that every time user entering the password, he must enter a \* first and enter a four-digit password within 9 seconds after the stop of the voice.*
- 3. When the user has entered the correct password, the voice system will broadcast Message 2-Correct password. Please enter the control code to control and then the user can do the following operation. If the password is wrong, the voice system will broadcast Message 3-Wrong password. Please re-enter. The user can only enter the wrong password three times. If the user enters the wrong password for the fourth time, SPR will hang up the telephone and stop broadcasting. And the system will then return to the main system. If the alarm status still exists, the voice system will dial automatically, for alarm purposes, every 40 seconds.*
- 4. When the alarm status exists, SPR voice module will broadcast the alarm voice repeatedly. It can be stopped by the use of the control function within the program.*
- 5. After SPR voice module has dialed if the user does not switch-off the alarm ON/OFF switch via the anti-control function i.e., the status of alarm is not eliminated, the voice module will dial, for alarm purpose, automatically every 40 seconds.*

*While recording, user must delete all the voice once the first time using the voice module before using. Otherwise the recorded voice may lose. As to the recorded voice messages, user may delete or modify randomly the voice message in them.*

And it has no effect on the other voice messages. As for the details, it is explained in the voice recording explanation.

#### 5.4 Explanation to Voice Software

Recording through the software:

Recording software is to record to the voice module via PC. And playing, saving the voice message, recording and playing online, password setup and information printing can all be realized through the software. Using the software to recording to the voice module, it is needed to record and save the recorded messages in PC through the software. And then write each voice message into the voice module via the communication cable. First it is need to learn how to use the recording software and then it is possible to correctly record to the voice module.

In the following we will introduce the recording software in details:

Start Software SuperRelayLogic and then click “Option | Sound Record” to enter the main interface:

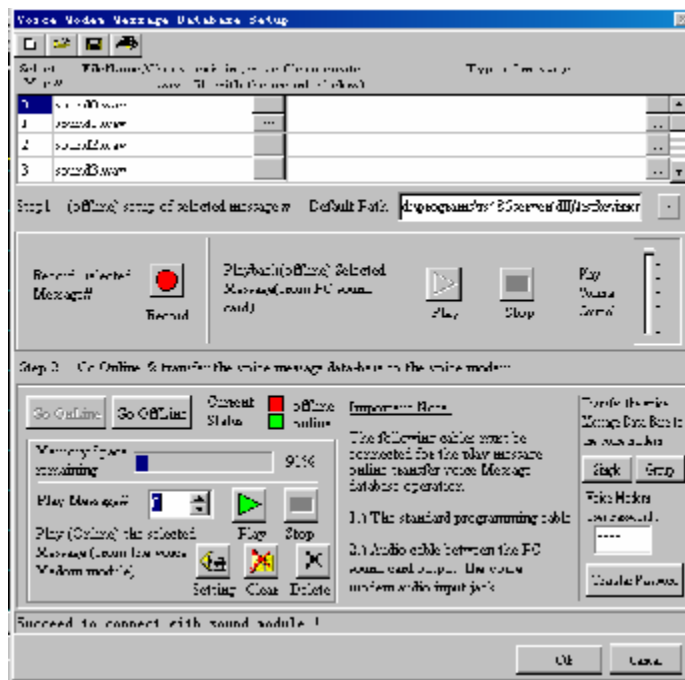

Fig. 5.4 PC Recording Main Interface

Function Explanation:

1. Newly build a voice information file

Select “” button, the following blank table will be displayed.

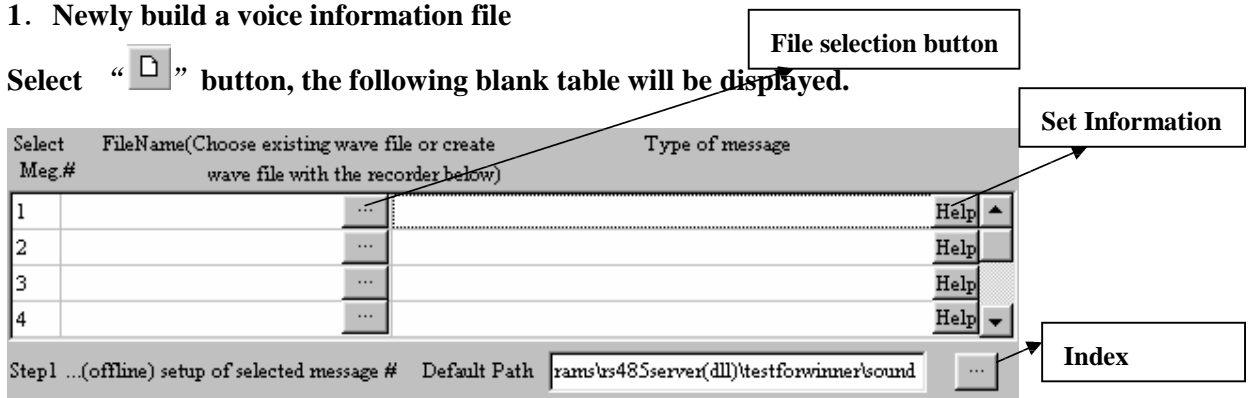



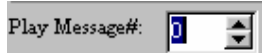

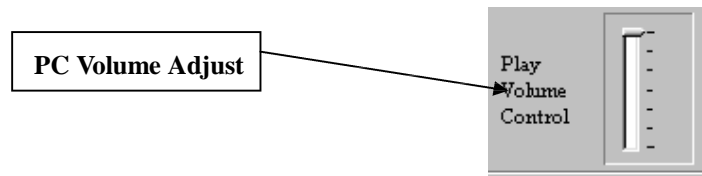

Fig. 5.5 Voice File Selection Dialogue Frame

2. **Save File:** Select button  and save the selected voice message. Enter the new file name.
3. **Open File:** Select button  and select one existed voice file.
4. **Print Information List:** Select button .
5. **PC Voice Play:** Select the playing voice message in  and then select button .
6. **Volume Adjust:**



**Fig. 5.6 Volume Adjust**

## 7. PC Recording Procedure

Select button  and enter into the following interface:

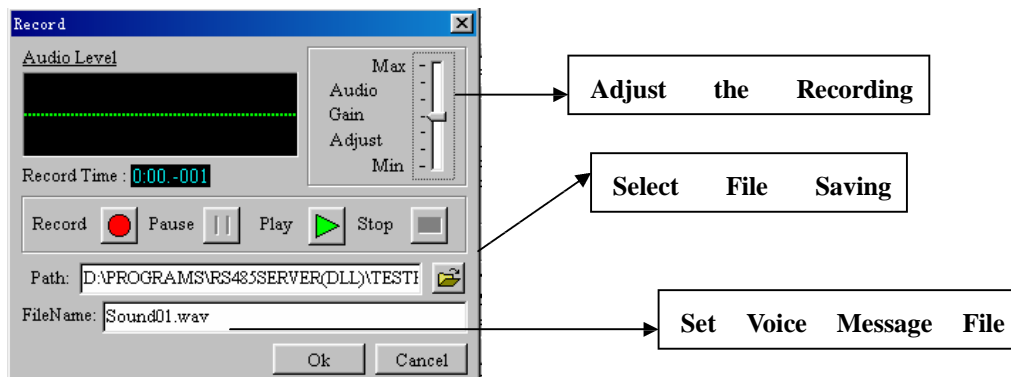

**Fig. 5.7 Recording Dialogue Frame**

7.1 **Select file saving folder:** Select button  and select the saving folder.

7.2 **Record voice message file name:** Enter the file name on the right of FileName.

7.3 **Record:** Select  and start recording from MIC. (Notes: Length of recording is 15 seconds.)

7.4 Select  and start to record this Message message.

8. **Select online:** Select button  and connect PC and voice module, SPR machine. If being successful, the following prompting dialogue frame will be displayed. At the same time the green indicator (Online) will flash without stopping. (Notes: Voice module must be connect well with SPR machine and connect the power.)



**Fig. 5.8 Successful Connection between PC, Voice Module and Machine Dialogue Frame**

**Notes:** The following functions can only be displayed and operated only after successful connection to .

**9. Memory Indicator:**   indicates the occupied memory of the voice message of the voice module.

**10.Voice Message Selection:** Select broadcasting or writing voice message via

**11. Play:** Click button  and start broadcast the voice module message.

**12. IPC download the voice to the voice module:** Select button  and write the selected message into the voice module.

If the relative voice file of the selected Message doesn't exist, this function button is forbidden to use. It must select the voice file first. The length of the voice file is 1-15 seconds, otherwise it is regarded ineffective.

**13. Batch download voice.** Select button  and then select all the voice Messages need to be written into the voice module. As shown in the following diagram:

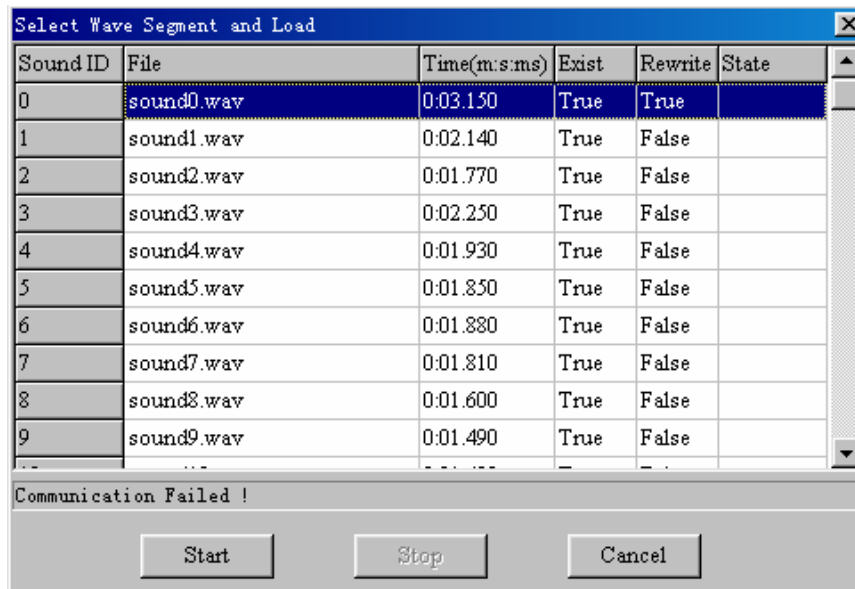

**Fig. 5.9 Batch Writing Voice Messages Selection Dialogue Frame**

Click the line and select the needed download voice messages. If needed, list the value of the REWRITE line be TRUE, otherwise being FALSE. After selecting click button START and download the message. If download successfully, the listed value

of the STATE is OK.

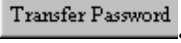
14. Set users' password': First enter the password (being 4 digit) and then click button .

15. Set audio tone: Select button . It will display audio tone set dialogue frame as the following.

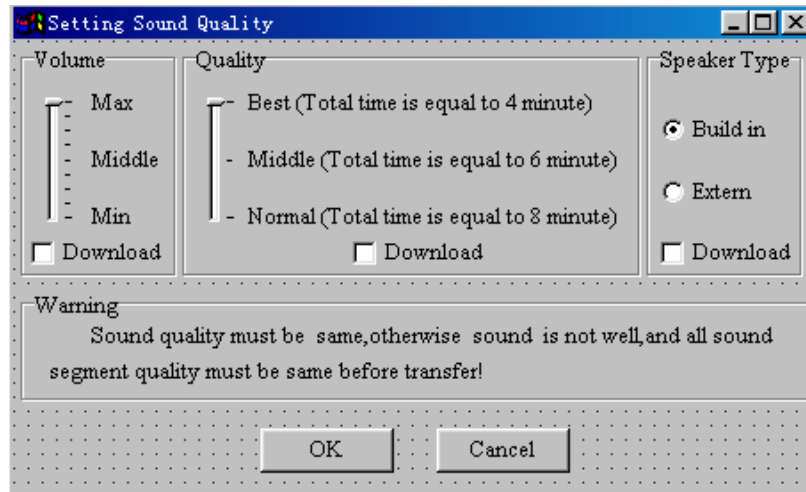

**Fig. 5.10 Voice Tone Setup Dialogue Frame**

System parameter set includes: Volume, Audio Tone & Speaker Type. After setting the specification values, if needed, select "Download" selection frame to download.

16. Clean out all voice messages: To select button  will clean out all the voice Messages in the voice module.

17. Delete voice Message: Select the deleting Message and then select button  to delete.

18. State Indicator: Indicate the current state

Playing progress : 43%

### 5.5 Recording Voice Message

After learning the recording software, it may record to the voice module via this software. In the following, we will introduce how to record series of voice Messages into the voice module in details.

#### Notes:

First time using voice module, deleting all the voice Messages once. Later users may directly record every time. No need to delete all the voice Messages.

Before recording, equip your PC with voice card and a microphone, otherwise the recording can't be carried out. Connect the wire as the following diagram:

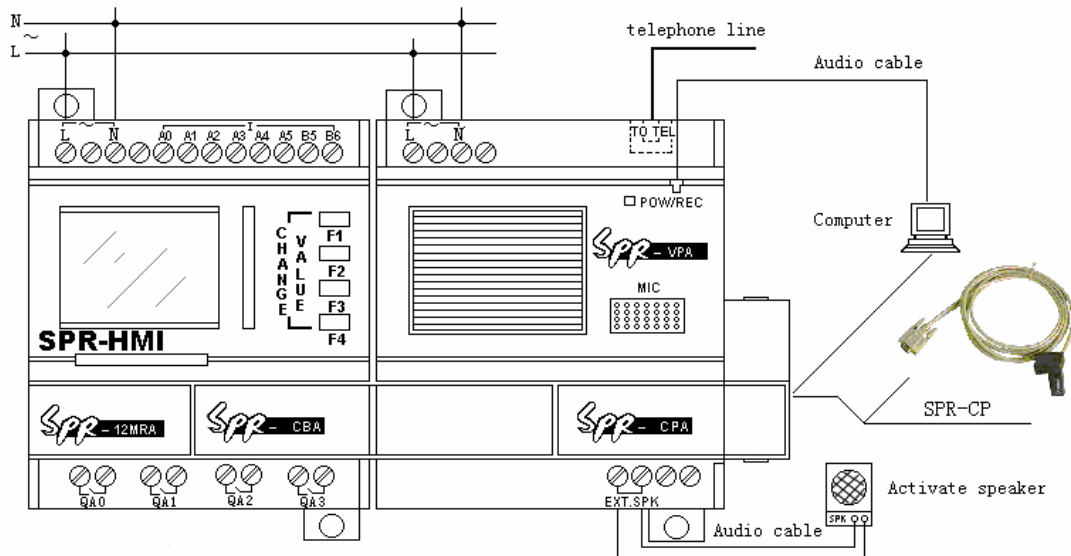

**Fig. 5.11 Wiring Diagram of Voice Module Recording**



**Fig. 1**



**Fig. 2**





**Fig. 3**

**Fig. 1:** Free audio wire accessory, to connect the voice audio input and PC audio output.

**Fig. 2:** SPR-CB, to connect the machine and the voice module and so on.

**Fig. 3:** SPR-CP Cable, the private connecting wire with PC series port.

**Recording Operation Procedures:**

1. Connect telephone, voice module and SPR machine rightly as the following diagram.
2. Connect the power of the voice module and SPR(Notes: Non-connecting of the power now).
3. Connect it with PC series port via SPR-PC.
4. Connect audio input of the voice module and audio output of PC via audio wire.
5. Confirm no failure of the connection and then power on. (Notes: Only machines of the same type can be connected together.)
6. Start SuperRelayLogic software and create a file and open relative series ports.
7. Start SuperRelayLogic software and click “Option | Sound Record” to enter the recording main interface as shown in Fig. 5.4.
8. Click button  in Fig. 5.4. The dialogue frame as shown in Fig. 5.7 will be displayed.
9. Click button  in Fig. 5.7 and start to record. Length of the recording voice message is better no longer than 15 seconds. (When recording, it is need to insert the microphone into the microphone input terminal of the PC voice card.)
10. After recording this Message, save it into the directed folder of the PC.

11. Record the second Message till all the voice Messages needed to be written into the voice module is completely recorded.

12. Then begin to write all the recorded Messages into the voice module. Click

**Go OnLine**

and connect successful. If it is the first time to record to the voice

module, click button  and delete all the Messages. If it is not the first time to record, directly do the next operations.

13. Select the relative voice message in Fig. 5.5 voice file selection dialogue frame

and open the voice message files that needed to write in. In

Play Message#: 0

select the voice Message that need to be written in and then click button **Single**.

Then this voice message will be written into the voice module. As shown in the following diagram:

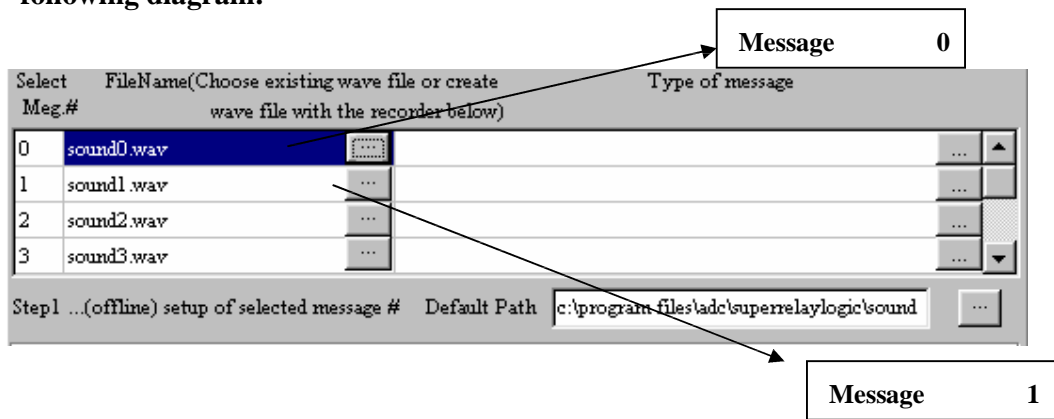

Notes: (1) Open Message 0 message that needed to write in “Meg#0” and open Message 1 message that needed to write in “Meg#1”. The rest may be deduced by analogy.

(2) If selected file is not under the current directory, it will be copy to current directory automatically. Thus it is easily to manage.

(3) The defaulted director is: \...\Sound. Generally it is no need to change.

14. If you want to write all the voice Messages into the voice module once, click button **Go OnLine** first and then click button **Group** after connecting successfully.

The batch writing in voice Messages selection dialogue frame is spring out. Select relative voice Message and then click button “Start”, thus all the voice Message will be written into the voice module in turns.

## Chapter VI Wireless remote control and extension module

### 6.1 Wireless Remote control function

The remote control function is to use a wireless transmitter and a receiver to control the ON/OFF status of outputs of SPR. There are 6 remote control points on the transmitter: Y1, Y2, Y3, Y4, Y5, Y6. The remote control distance can reach 100 m. And this is a very outstanding feature of SPR.

#### 6.1.1 The structure of receiver and transmitter

The remote control system needs to use together with the SPR main machine. It can be divided into receiver part and transmitter part.

Their structure is as following:

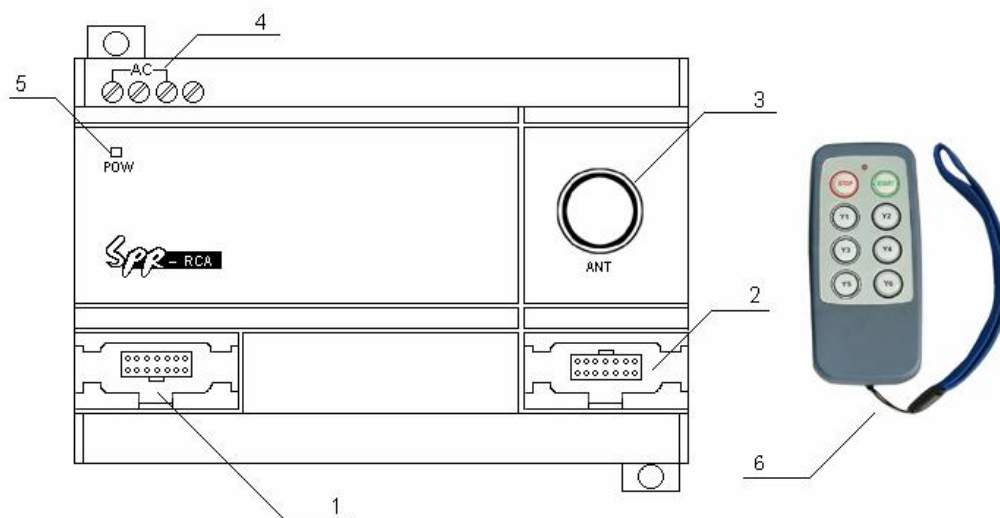

Fig6.1 Remote control system

1. The interface to SPR or Voice module.
2. The communication port to connect receiver to Computer or next extension module.
3. The antenna of receiver
4. The power terminals of receiver (AC100-240V or DC12-24V) .
5. Indicator light for power on.
6. SPR-TC transmitter.

#### 6.1.2 The connection method between receiver and SPR or Voice module.

There are 2 types of receiver module, SPR-RCA (AC type) and SPR-RCD (DC type), the receiver can be connected to the same type (AC or DC type) of SPR and voice module to realize the wireless remote control of the I/O for SPR and voice module.

1. The connecting diagram of SPR-RCA and SPR-12MRA, SPR-VPA The AC type receiver and AC type SPR, AC type voice module can be used together, SPR-RCA can work with SPR-12MRA, SPR-22MRA or SPR-VPA, and at the same time, the system can extended to connect 5 pcs of SPR-20ERA.

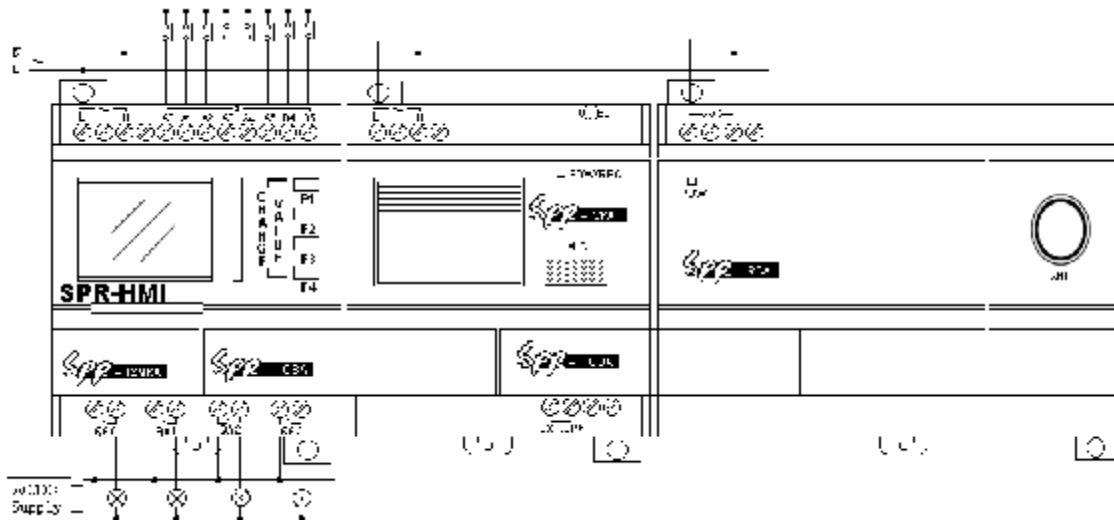

**Fig6.2 SPR-RCA connected to SPR-12MRA and SPR-VPA**

2. **SPR-RCD connected to SPR-12MRD and SPR-VPD** The DC type receiver and DC type SPR, DC type voice module can be used together, SPR-RCD can work with SPR-12MRD, SPR-12MTD, SPR-22MRD, SPR-22MTD or SPR-VPD, and at the same time, the system can extended to connect 5 pcs of SPR-20ERD.

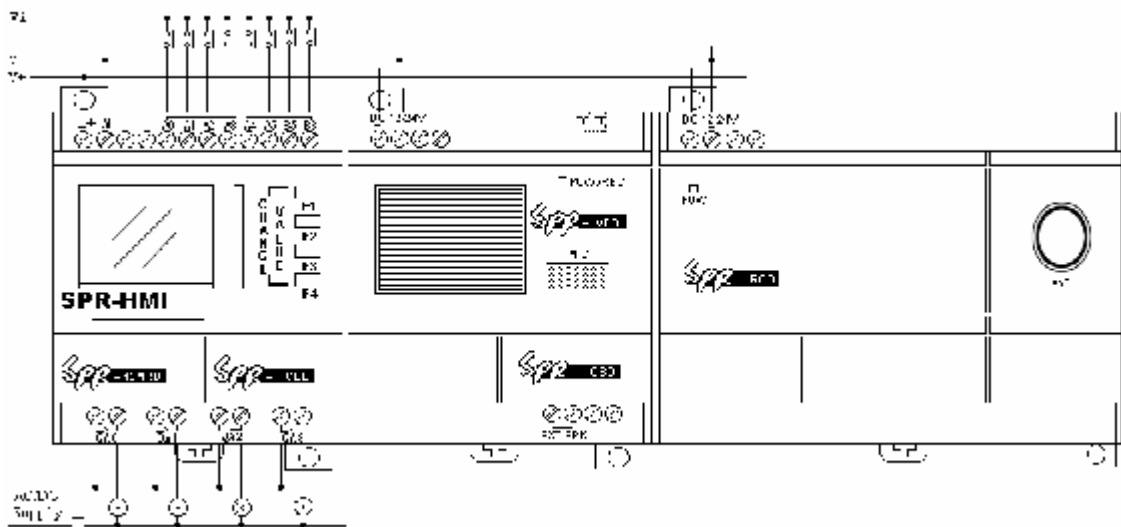

**Fig6.3 SPR-RCD connected to SPR-12MRD and SPR-VPD**

### 3. SPR-RCD connected to SPR-12MTD and SPR-VPD

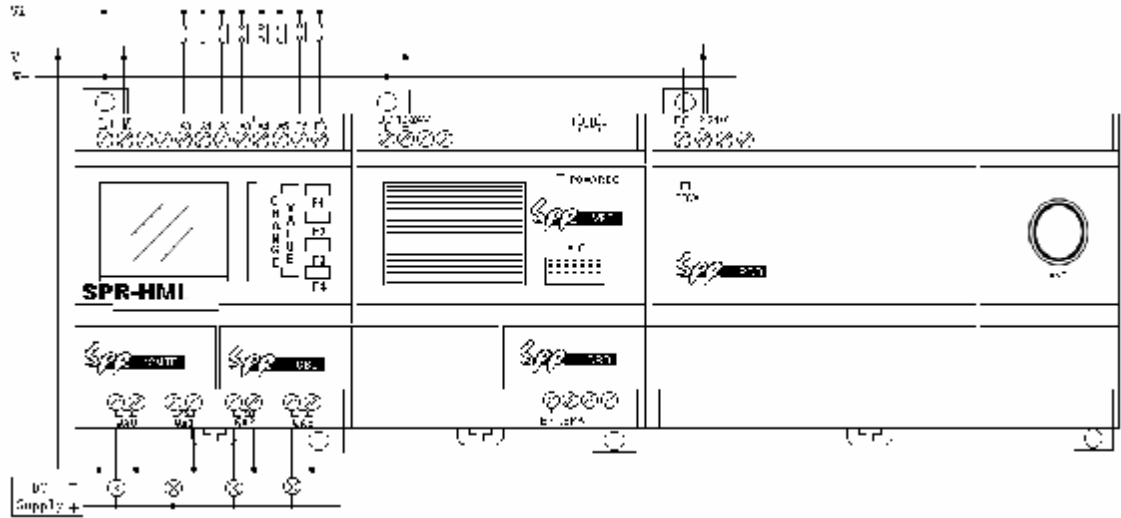
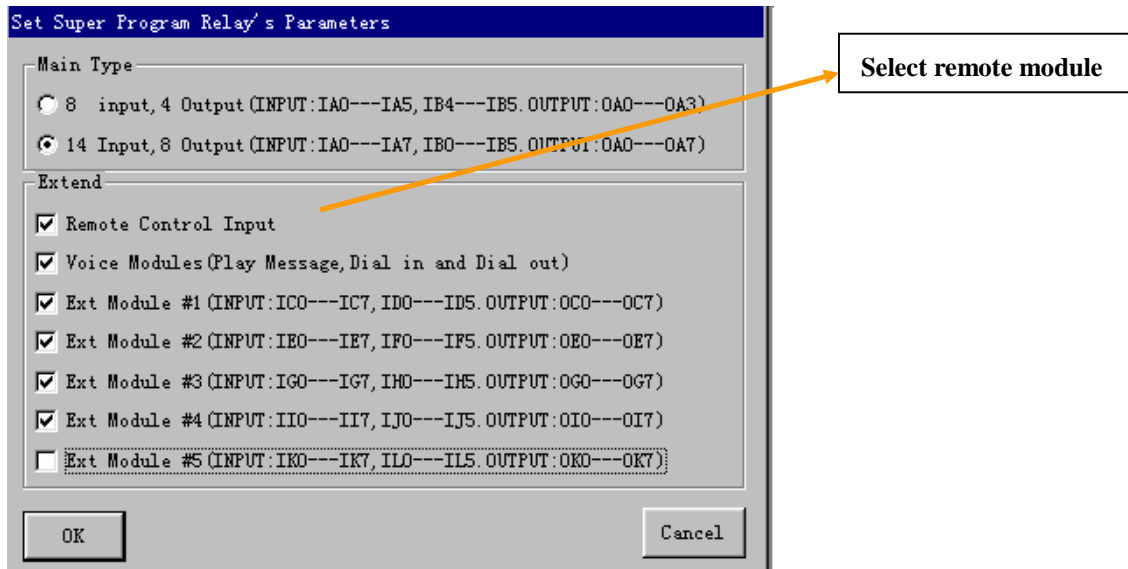

Fig6.4 SPR-RCD connected to SPR-12MTD and SPR-VPD

 **Notes:**

1. Only the same type (AC or DC) can be used together.
2. One SPR main machine can extend to connect 5 extension module.(Same AC or DC type).
3. The transmitter can control the I/O of the SPR or Extension module.
4. User must edit the Remote control instruction in control program, such as

Fig.6.5



## 6.2 Extension module

Extension module can be connected to the same type of SPR main machine to extend the I/O, each extension module has 12I/8O, one SPR can be connected to 5 extension module one by one. Such as that SPR-22 can be connected to 5 SPR-20 to reach 74I/48O. This powerful extension function brings you much easier to do the control system, and also lower you cost very greatly. The I/O of extension module is divided as:

Inputs of No.01 extension module are IC0~IC7, ID0~ID3,

Inputs of No.02 extension module are E0~IE7, IF0~IF3,

Inputs of No.03 extension module are IG0~IG7, IH0~IH3,

Inputs of No.04 extension module are II0~II7, IJ0~IJ3

Inputs of No.05 extension module are IK0~IK7, IL0~IL3.

Outputs of No.01 extension module are QC0~QC7

Outputs of No.02 extension module are QE0~QE7

Outputs of No.03 extension module are QG0~QG7

Outputs of No.04 extension module are QI0~QI7

Outputs of No.05 extension module are QK0~QK7

### 6.2.1 The extension module structure

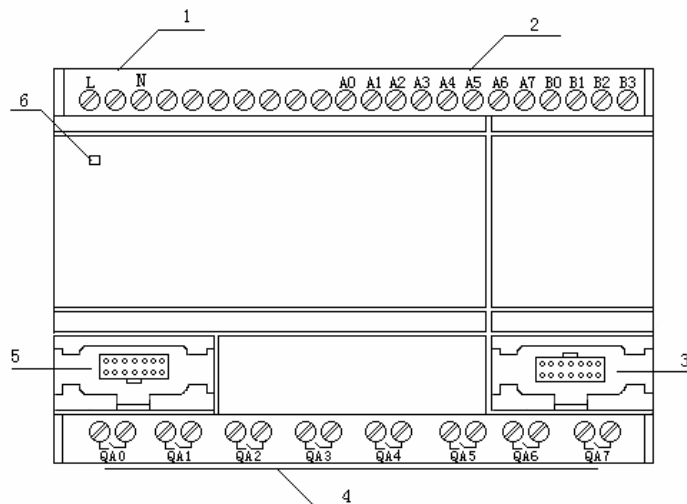

Fig6.5 Extension module structure

1. Power supply terminals (AC100-240V or DC12-24V)
2. Input terminals
3. Communication port to voice module , voice module or receiver module
4. Output terminals
5. Communication port to SPR main machine
6. Power indicator light

### 6.2.2 Extension module address setting

SPR series product can be connected to 5 extension module at the most, we need to give each extension module an address. So we defined their address as 1~5. The system will work correctly only after setting the correct address. The address setting is as in Fig.6.6. EXT1~EXT5 are the No.1 to No.5 extension modules.

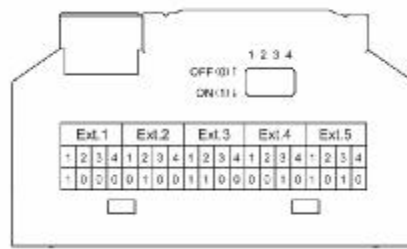

Fig. 6. 6

### 6.2.3 The types and connection of extension module

1. SPR-20ERA (AC power and relay outputs) can work connected to SPR-12MRA or SPR-22MRA

The connection diagram of SPR-20ERA and SPR-12MRA:

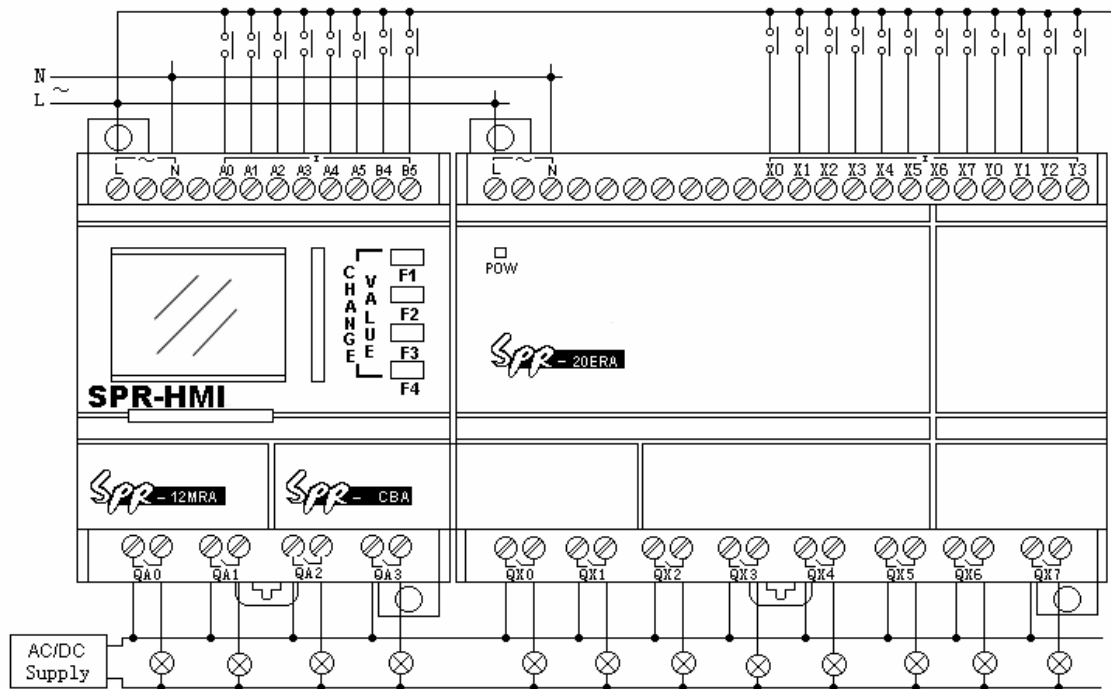

Fig.6.7 SPR-20ERA connected to SPR-12MRA

**Danger**

1. Current safety regulations do not permit the connection of different phases to the input.
2. Power and input must same phases
3. Do not touch of the input and output points and power input points at SPR working.
4. Don't touch or take down the link bridge SPR-CBA/CBD at SPR working.

2. SPR-20ERD (DC power and relay outputs) can work connected to SPR-12MRD or SPR-22MRD.

**The connection diagram of SPR-20ERD and SPR-12MRD:**

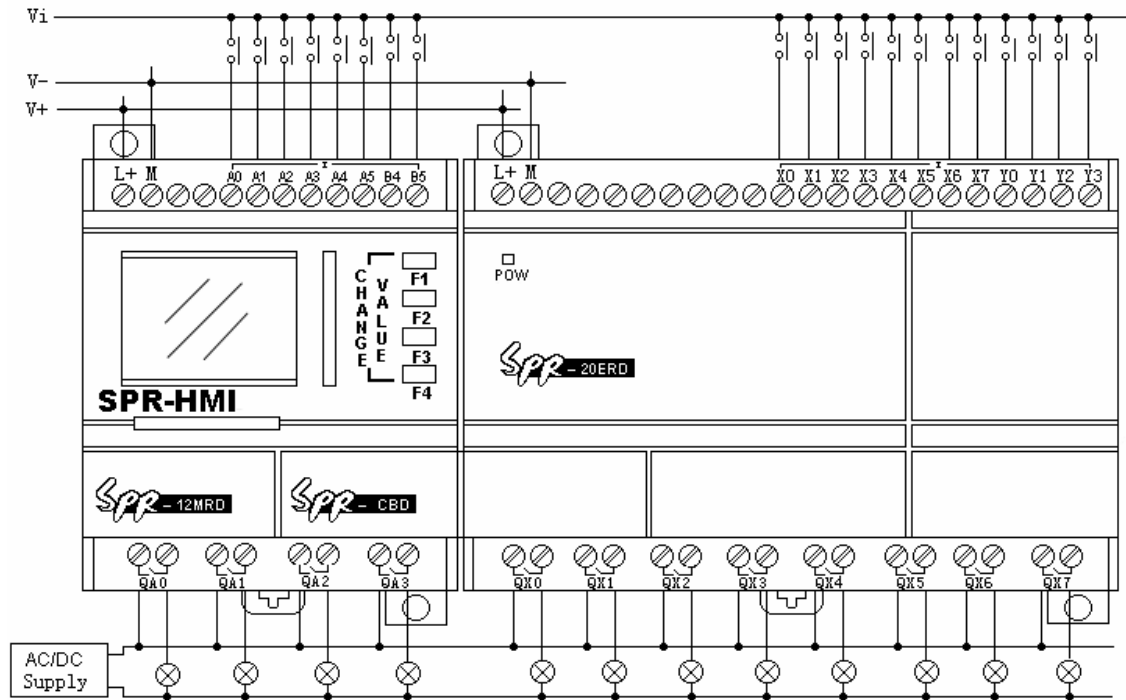

**Fig6.8 SPR-20ERD connected to SPR-12MRD**

**3. SPR-20ETD (DC power and transistor outputs) can work connected to SPR-12MTD or SPR-22MTD.**

**The connection diagram of SPR-20ETD and SPR-12MTD:**

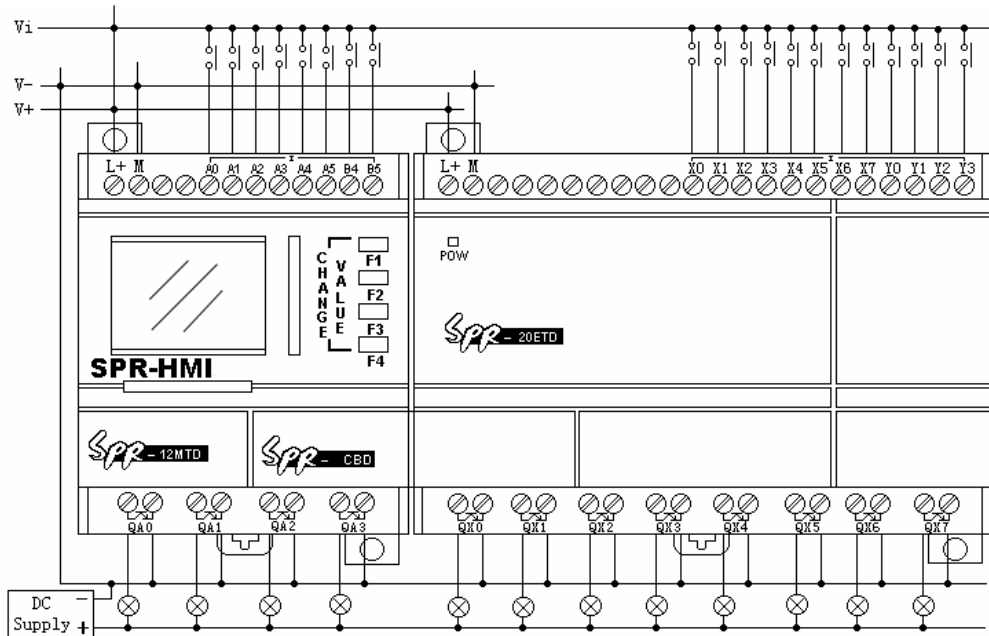

**Fig 6.9 SPR-20ETD connected to SPR-12MTD**



**Note:**

**1. The extension module can be only connected to the same type of SPR main**

machine, it means that the AC type should work together with AC type SPR main machine, and DC type should work together with DC type, and transistor type should work together with transistor type.

2. One SPR main machine can be connected to 5 same type extension module at the most. ◦
3. The address of each extension module should be different to others. Must be in the range of 1-5.
4. To use the extension module after connecting them to the main machine, we must choose the relative extension module at the beginning of edit the control program, or we can not program them. See the following fig.

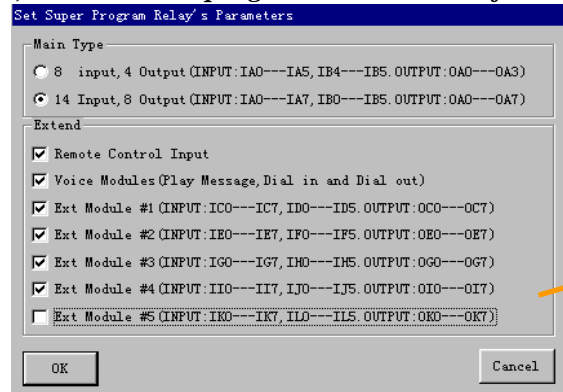

Ext module1~5

Fig 6.10 Configure extension module in the software

### 6.3 SPR series products and optional parts



Fig. 1 SPR-12 Series PLC



Fig. 2 SPR-VPA/VPD Voice/Telephone



Fig. 3 SPR-22 Series PLC



Fig. 4 SPR-CP



Fig. 5 SPR-CB



Fig. 6 SPR-ECB



Fig. 7 SPR-EHC



**Fig. 8 SPR-RCA/RCD Remote Controller Module**



**Fig. 9 SPR-TC Module**  
**Fig. 10 SPR-20E Series Extend Module**



Short circuit protection cos0.5~0.7	Power protection B16 600A	Power protection B16 600A
Output relay protection	B16 Max 20A	B16 Max 20A
ON/OFF frequency:		
Mechanical frequency	10Hz	10Hz
Resistor load/light load	2Hz	2Hz
Inductive load	0. 5Hz	0. 5Hz

## 7.2 SPR-12MRD/SPR-22MRD technical parameters

Type Parameter	SPR-12MRD SPR-12MRDC SPR-12MRDK	SPR-22MRD SPR-22MRDC SPR-22MRDK
<b>Power:</b>		
Power voltage	12~24VDC	12~24VDC
Clock remain time at 25•	80 Hours	80 Hours
Real time clock accuracy	Max ±5s/day	Max ±5s/day
<b>Inputs:</b>		
Input points	8 (A0~A5, B4~B5)	14 (A0~A7, B0~B5)
Digital inputs	8 (A0~A5, B4~B5)	12(A0~A7, B0~B3)
Analogue inputs	6(A0~A5)	8(A0~A7)
Input voltage range	0~24VDC (digital inputs)	0~24VDC (digital inputs)
	0~10VDC (analogue inputs)	0~10VDC (analogue inputs)
Input signal 0	0~5VDC	0~5VDC
Input signal 1	10~24VDC	10~24VDC
Delay time from 1 to 0	50ms	50ms
Delay time from 0 to 1	50ms	50ms
<b>Relay output</b>		
Output points	4(QA0~QA3)	8(QA0~QA7)
Output type	Relay Output	Relay Output
Output voltage	0~240VAC	0~240VAC
	0~24VDC	0~24VDC
Output current	Resistor load 10A	Resistor load 10A
	Inductive load 2A	Inductive load 2A
Response time from 1 to 0	8ms	8ms
Response time from 0 to 1	10ms	10ms
Light Load (25,000 Switch Cycle)	1000W(230/240VAC) 500W(115/120VAC)	1000W(230/240VAC) 500W(115/120VAC)

Fluorescence Light with electronics controlling equipments (25,000 Switch Cycle)	10x58W(230/240VAC)	10x58W(230/240VAC)
Fluorescence Tube with conventional compensation (25,000 Switch Cycle)	1x58W(230/240VAC)	1x58W(230/240VAC)
Fluorescence Tube without compensation (25,000 Switch Cycle)	10x58W(230/240VAC)	10x58W(230/240VAC)
Short circuit protection cos1	Power protection B16 600A	Power protection B16 600A
Short circuit protection cos0.5~0.7	Power protection B16B16 600A	Power protection B16 600A
Relay output protection	B16 Max 20A	B16 Max 20A
ON/OFF frequency:		
Mechanical frequency	10Hz	10Hz
Resistor load/light load	2Hz	2Hz
Inductive load	0. 5Hz	0. 5Hz

### 7.3 SPR-12MTD/SPR-22MTD technical parameters

Type Parameter	SPR-12MTD SPR-12MTDC SPR-12MTDK	SPR-22MTD SPR-22MTDC SPR-22MTDK
<b>Power:</b>		
Power voltage range	12~24VDC	12~24VDC
Clock remain time at 25°	80 Hours	80 Hours
Real time clock accuracy	Max ±5s/day	Max ±5s/day
<b>Inputs:</b>		
Input points	8 (A0~A5, B4~B5)	14 (A0~A7, B0~B5)
Digital inputs	6(A0~A5)	12(A0~A7, B0~B3)
Analog inputs	6(A0~A5)	8(A0~A7)
High speed inputs	2(B4~B5)	2(B4~B5)
Input voltage range	0~24VDC (digital)	0~24VDC (digital)
	0~10VDC (analog)	0~10VDC (analog)
Input signal 0	0~5VDC	0~5VDC
Input signal 1	10~24VDC	10~24VDC
Delay time from 1 to 0	50ms	50ms
Delay time from 0 to	50ms	50ms

<b>1</b>		
<b>Transistor outputs:</b>		
<b>Output points</b>	<b>4(QA0~QA3)</b>	<b>8(QA0~QA7)</b>
<b>Output types</b>	<b>Transistor output</b>	<b>Transistor output</b>
<b>Output voltage</b>	<b>0~24VDC</b>	<b>0~24VDC</b>
<b>Output current</b>	<b>2A</b>	<b>2A</b>
<b>Response time from 1 to 0</b>	<b>8ms</b>	<b>8ms</b>
<b>Response time from 0 to 1</b>	<b>8ms</b>	<b>8ms</b>

#### 7.4 SPR-20ERA/SPR-20ERD/SPR-20ETD technical parameter

##### 1. SPR-20ERA technical parameter

Type Parameter	SPR-20ERA
<b>Power</b>	
<b>Power voltage range</b>	<b>100~240VAC</b>
<b>Inputs:</b>	
<b>Input points</b>	<b>12 (X0~X7, Y0~Y3)</b>
<b>General digital inputs</b>	<b>12(X0~X7, Y0~Y3)</b>
<b>Input voltage range</b>	<b>0~240VAC</b>
<b>Input signal 0</b>	<b>0~40VAC</b>
<b>Input signal 1</b>	<b>85~240VAC</b>
<b>Delay time from 1 to 0</b>	<b>50ms</b>
<b>Delay time from 0 to 1</b>	<b>50ms</b>
<b>Relay outputs:</b>	
<b>Output points</b>	<b>8(QX0~QX7)</b>
<b>Output type</b>	<b>Relay outputs:</b>
<b>Output voltage</b>	<b>0~240VAC</b>
	<b>0~24VDC</b>
<b>Output current</b>	<b>Resistor load: 10A</b>
	<b>Inductive load: 2A</b>
<b>Response time from 1 to 0</b>	<b>8ms</b>
<b>Response time from 0 to 1</b>	<b>10ms</b>
<b>Light Load (25,000 Switch Cycle)</b>	<b>1000W(230/240VAC) 500W(115/120VAC)</b>
<b>Fluorescence Light with electronics controlling equipments (25,000 Switch Cycle)</b>	<b>10x58W(230/240VAC)</b>

<b>Fluorescence Tube with conventional compensation (25,000 Switch Cycle)</b>	<b>1x58W(230/240VAC)</b>
<b>Fluorescence Tube without compensation (25,000 Switch Cycle)</b>	<b>10x58W(230/240VAC)</b>
<b>Short circuit protection cos1</b>	<b>Power protection B16 600A</b>
<b>Short circuit protection cos0.5~0.7</b>	<b>Power protection B16 600A</b>
<b>Output relay protection</b>	<b>B16 Max 20A</b>
<b>ON/OFF frequency:</b>	
<b>Mechanical frequency</b>	<b>10Hz</b>
<b>Resistor load/ light load</b>	<b>2Hz</b>
<b>Inductive load</b>	<b>0. 5Hz</b>

## 2. SPR-20MRD technical parameter

Type Parameter	SPR-20ERD
<b>Power:</b>	
<b>Power voltage range</b>	<b>12~24VDC</b>
<b>Inputs:</b>	
<b>Input points</b>	<b>12 (X0~X7, Y0~Y3)</b>
<b>Digital inputs</b>	<b>12(X0~X7, Y0~Y3)</b>
<b>Input voltage range</b>	<b>0~24VDC (Digital inputs)</b>
<b>Input signal 0</b>	<b>0~5VDC</b>
<b>Input signal 1</b>	<b>10~24VDC</b>
<b>Delay time from 1 to 0</b>	<b>50ms</b>
<b>Delay time from 0 to 1</b>	<b>50ms</b>
<b>Relay outputs:</b>	
<b>Output points</b>	<b>8(QX0~QX7)</b>
<b>Output type</b>	<b>Relay Output</b>
<b>Output voltage</b>	<b>0~240VAC</b>
	<b>0~24VDC</b>
<b>Output current</b>	<b>Resistor load: 10A</b>
	<b>Inductive load: 2A</b>
<b>Response time from 1 to 0</b>	<b>8ms</b>
<b>Response time from 0 to 1</b>	<b>10ms</b>

<b>Light Load (25,000 Switch Cycle)</b>	<b>1000W(230/240VAC) 500W(115/120VAC)</b>
<b>Fluorescence Light with electronics controlling equipments (25,000 Switch Cycle)</b>	<b>10x58W(230/240VAC)</b>
<b>Fluorescence Tube with conventional compensation (25,000 Switch Cycle)</b>	<b>1x58W(230/240VAC)</b>
<b>Fluorescence Tube without compensation (25,000 Switch Cycle)</b>	<b>10x58W(230/240VAC)</b>
<b>Short circuit protection cos1</b>	<b>Power ProtectionB16 600A</b>
<b>Short circuit protection cos0.5~0.7</b>	<b>Power ProtectionB16 600A</b>
<b>Output relay protection</b>	<b>B16      Max 20A</b>
<b>ON/OFF frequency:</b>	
<b>Mechanical frequency</b>	<b>10Hz</b>
<b>Resistor load/light load</b>	<b>2Hz</b>
<b>Inductive load</b>	<b>0. 5Hz</b>

### 3. SPR-20ETD technical parameter

<b>Type Parameter</b>	<b>SPR-20ETD</b>
<b>Power</b>	
<b>Power voltage range</b>	<b>12~24VDC</b>
<b>Inputs:</b>	
<b>Input points</b>	<b>12 (X0~X7, Y0~Y3)</b>
<b>Digital inputs points</b>	<b>12(X0~X7, Y0~Y3)</b>
<b>Input voltage range</b>	<b>0~24VDC</b>
<b>Input signal 0</b>	<b>0~5VDC</b>
<b>Input signal 1</b>	<b>10~24VDC</b>

Delay time from 1 to 0	50ms
Delay time from 0 to 1	50ms
<b>Transistor output :</b>	
Output points	8(QX0~QX7)
Output type	Transistor output
Output voltage	0~24VDC
Output current	2A
Response time from 1 to 0	8ms
Response time from 0 to 1	8ms

### 7.5 Voice module technical parameter

Parameter	Conform standard
Receive signal automatically	CCITT-DTMF
Sent signal automatically	CCITT-DTMF
Record message	Record message Total 100 messages, the max length of each message is 15 seconds, and the total message length is 8 minutes

### 7.6 Remote receiver technical parameter

Items	Parameter
Power cost	1. 5W
Work frequency	VHF,UHF
Control distance	≤100 meters

### 7.7 SPR series general technical parameter

Items	Standard	Conditions
<b>Weather environment:</b>		
Environment temperature	Cold: IEC-68-2-1	
	Hot: IEC-202	
Horizon installation		0~55°
Vertical installation		0~55°
Store/transportation		-40° to +70°
Relative humidity	IEC68-2-30	From 5% to 95% without condensation
Air pressure		From 795 to 1080Kpa
Pollution	IEC68-2-42	SO2 10cm3/m3,4 days
	IEC-68-2-43	H2S1CM2/m3,4 days
<b>Mechanical conditions:</b>		
Protection type	54	IP20

<b>Vibration</b>	<b>IEC68-2-6</b>	<b>From 10 to 57Hz (constant vibration length at 0.15mm) From 57 to 150Hz (constant acceleration speed 2g)</b>
<b>Brunt</b>	<b>IEC68-2-27</b>	<b>18 times (half sine 15g/11ms)</b>
<b>Fall</b>	<b>IEC68-2-31</b>	<b>Falling high 50mm</b>
<b>Free falling down (with package)</b>	<b>IEC68-2-32</b>	<b>1m</b>
<b>EMC:</b>		
<b>Static electricity discharge Level 3 8Kv air discharge, 6kVcontact discharge</b>	<b>Level 3</b>	<b>8Kv air discharge, 6kVcontact discharge</b>
<b>Electromagnetic field</b>	<b>IEC801-3</b>	<b>Field density 10V/M</b>
<b>Anti-interference</b>	<b>EN55011</b>	<b>Limit class B 1</b>
<b>Surge Pulse</b>	<b>IEC801-4 Level 3</b>	<b>2KV (power line) 2KV (signal line)</b>
<b>IEC/VDE safety</b>		
<b>Insulation density</b>	<b>IEC1131</b>	<b>Reach requirement</b>

## Chapter VIII Application

SPR has a very wide application range. In order to let the user consider the wide application potential for SPR and the convenience brought about by its use, we will show some common and representative control schemes herein. After the user has read these application examples it will be clear how simple it is to use SPR to establish automatic control requirements, especially in a system requiring time control and in the automatic control of intelligent living quarters etc.

### 8.1 the illumination of Multifunction switch in stairs, halls etc.

**Requirement:**

1. When the light switch has been pressed, the illumination will be connected and then be cut off automatically after the set time of 3 minutes.
2. Lights glimmer for 5 seconds before being switched off.
3. When the switch is pressed again, the illumination will be on as usual.
4. When the switch is pressed for more than 2 seconds the illumination will be on as usual.
5. The illumination will be automatically connected every day at PM6:30 and be cut off every day at AM6:30.

The Function Block Program Diagram 3 seconds as follows:

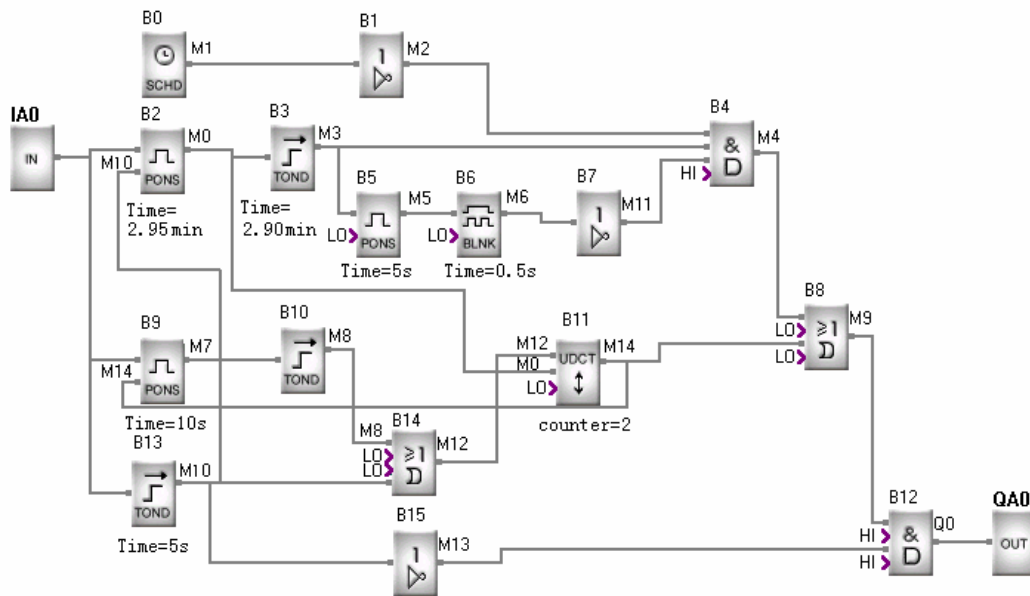

### 8.2 Automatic gate control requirements:

**Requirement:**

1. Opening and closing of the gate shall be controlled by the guard in the control room.
2. Normally the gate shall be opened or closed completely, but the opening and closing action can be interrupted at any time.
3. The alarm lamp shall begin to flash when the gate acts and shall keep flashing as long as the gate continues to move.
4. A pressure damper shall be provided so that the gate can be automatically opened when it touches a person or an article.

The Function Block Program Diagram is as follows:





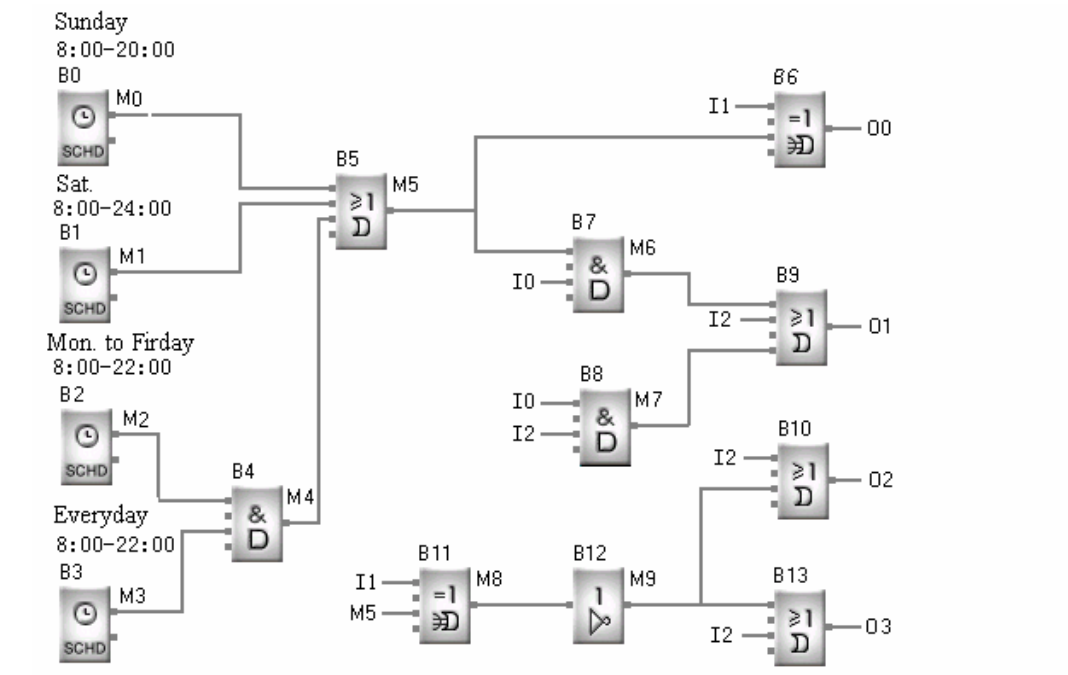

*Note:*

- I0 shall be connected to the light sensitive switch;*
- I1 to the auto/manual selection switch;*
- I2 to the test switch;*
- Q1 to the basic lighting in display period;*
- Q1 to the night additional lighting within display period;*
- Q2 to the minimum illumination maintaining during non-display period;*
- Q3 to the projection light for special commodities in non-display period.*

### 8.5 Automatically Supplying system of the Tower

**Requirement:**

1. The pressure signal (P1) is entered. If  $P1 < 7V$ , the #1 pump will be started.
2. If  $P1 < 3V$ , the #2 pump will be started.
3. If  $P1 < 1V$ , it will wait for 5 seconds. After that if it is still  $< 1V$ , the voice alarming function will be started.

Here we adopt the SPR-12MRD and SPR-VPD to realize the function.

The  
diagram:

wiring

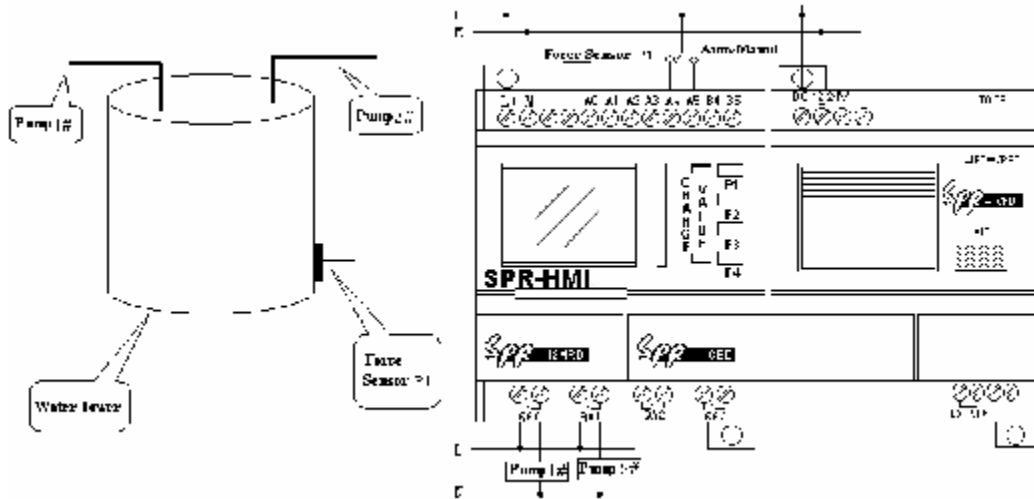

**Control Program:**

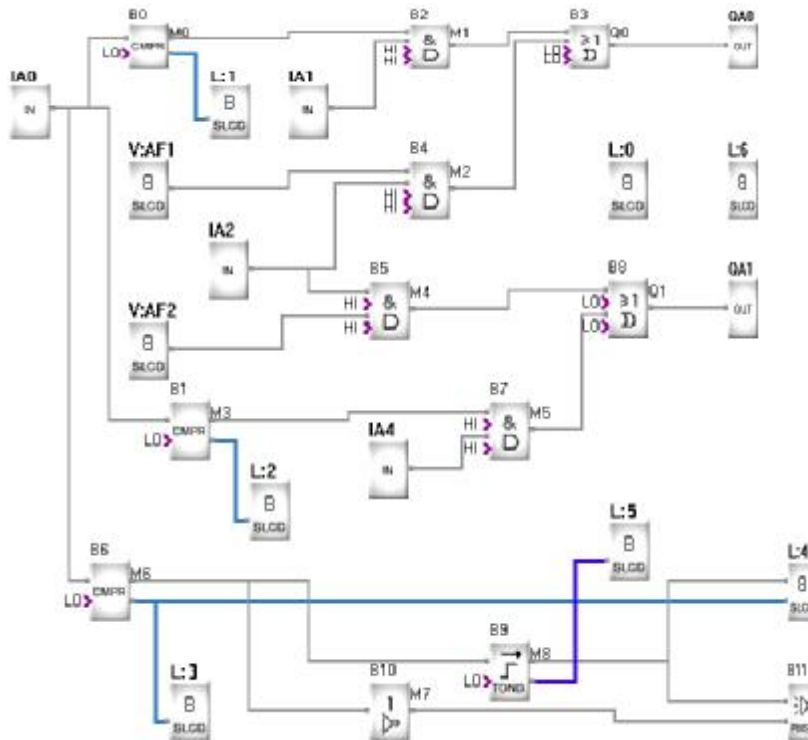

**2. Explanation:**

a. SPR-12MRD controls the pressure sensor P1 that entering the pressure signal. If  $P1 < 7V$ , the #1 Pump will be started; if  $P1 < 3V$ , the #2 Pump will be started; if  $P1 < 1V$ , it will wait for 5 seconds and if the condition is still, the voice alarming function will be started.

b. SA is the Handle/Auto switch. I4 and I5 are separately connected.

c. If SA is Handle, SPR-12MRD has two function keys: AF1, which controls the #1 pump, and AF2, which controls the #2 pump.

d. If SA is Auto, SPR-12MRD has three analog comparisons B0, B1, B6. The parameters setup is as the following:

<input type="checkbox"/> Input 1	<input type="radio"/> =	<input checked="" type="checkbox"/> Input 2	Turn On Output
Fixed value	<input type="radio"/> !=	Fixed value	
0	<input type="radio"/> <	7	
0.0---10.0	<input type="radio"/> >	0.0---10.0	
Max	<input type="radio"/> <=	10	
0	<input type="radio"/> >=	Min	
Min		0	
0		0	

**B0**

<input type="checkbox"/> Input 1	<input type="radio"/> =	<input checked="" type="checkbox"/> Input 2	Turn On Output
Fixed value	<input type="radio"/> !=	Fixed value	
0	<input type="radio"/> <	3	
0.0---10.0	<input type="radio"/> >	0.0---10.0	
Max	<input type="radio"/> <=	10	
0	<input type="radio"/> >=	Min	
Min		0	
0		0	

**B1**

<input type="checkbox"/> Input 1	<input type="radio"/> =	<input checked="" type="checkbox"/> Input 2	Turn On Output
Fixed value	<input type="radio"/> !=	Fixed value	
0	<input type="radio"/> <	1	
0.0---10.0	<input type="radio"/> >	0.0---10.0	
Max	<input type="radio"/> <=	10	
0	<input type="radio"/> >=	Min	
Min		0	
0		0	

**B6**

e. B0 controls the #1 pump; B1 controls the #2 pump and B6 controls the voice alarming function.

f. Editing HMI. In this example, there are 7 HMIs. The explanation is as the following:

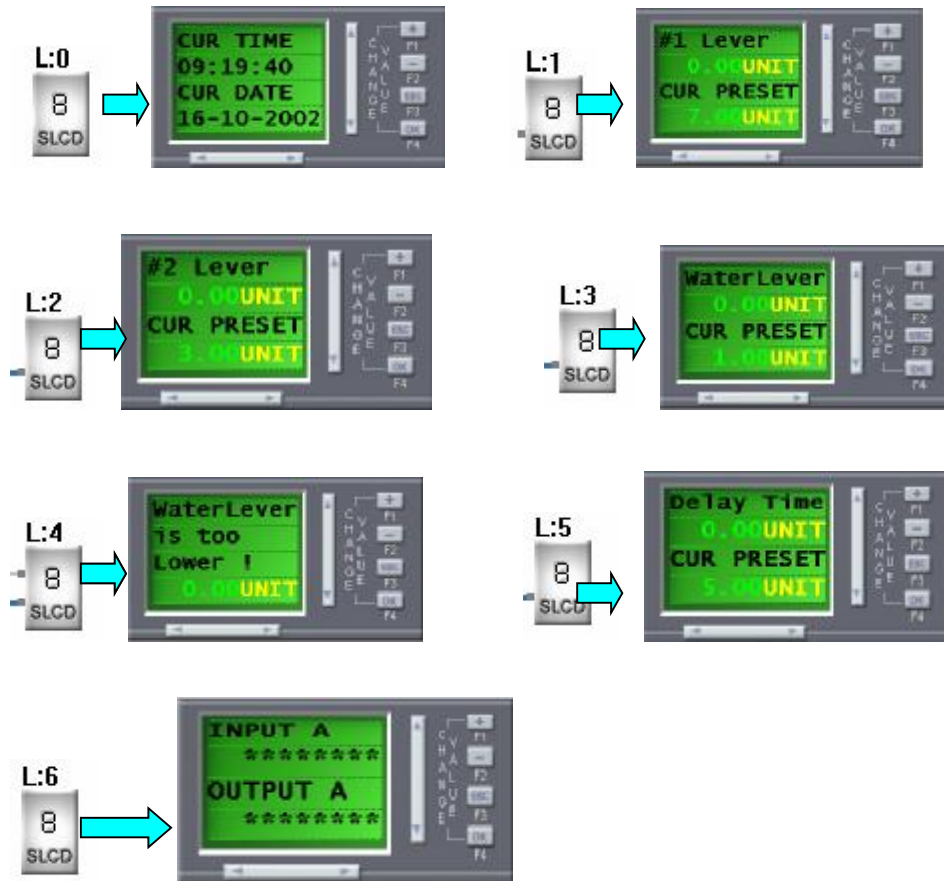

## **Chapter IX Quality Guarantee**

### **Quality Guarantee**

The product has been strictly tested for quality before delivery from our plant and it complies with (as appropriate) all product requirements listed in this manual. When properly installed it will work in accordance with its' specifications.

### **Warranty Period**

This product is warranted against defects in material and manufacturing for a period of one year from the date of delivery. During the warranty period, ARRAY shall be responsible for necessary repairs or replacement, as long as the product is proven to be inherently defective.

### **Warranty Range**

During the above mentioned Warranty Period, if the product is fails to perform in accordance with its' specifications and has not been misused it shall be delivered to a service centre, which ARRAY authorizes, for free repair. ARRAY reserves the right to repair or replace the product in accordance with it's discretion. In the event of product replacement the buyer will be informed and shall be responsible for reloading software, unless agreed otherwise.

The buyer shall pay the shipping charge for delivery to the ARRAY service centre and the ARRAY service centre will repair or replace the product and deliver it to the buyer free of charge.

The above warranty does not include the following circumstances.

- 1. Improper installation testing or operation**
- 2. Misuse**
- 3. Damage caused by unauthorized dismantling of the product**
- 4. Damage to consumable parts such as rubber cover, buttons, batteries, relays etc.**

### **Declaration:**

As the hardware and software contents of this manual has been seriously checked in detail and sometimes mistakes is not avoidable, the manual is not completely correct. We will check the manual in time and revise the necessary in the next version. Your proposal is welcome.